

SMEC

PL 2000 Series

CNC TURNING CENTER



SMEC SMEC CO.,LTD.

SMEC Co., Ltd.

157-10, Goldenroot-ro, Juchon-myeon, Gimhae-si,
Gyeongsangnam-do, Korea
Tel +82 55 340 4800 / Fax +82 55 340 4740
www.esmec.com



PL 2000 Series

- PL 2000A
- PL 2000B
- PL 2000AM
- PL 2000BM

❖ Design and specifications subject to change without notice.

© SMEC 2021.02-NO.1

- 1988 - Started as Samsung Heavy Industries Machine Tools Business
- 1989 - Horizontal and vertical machining center technology partnership with OKK Japan
- 1991 - Turning center and vertical machining center technology partnership with Mori Seiki
- 1996 - 5-sided processing center technology partnership with Toshiba
- 1999 - Spun out from Samsung Aerospace Industries and established SMEC Co., Ltd

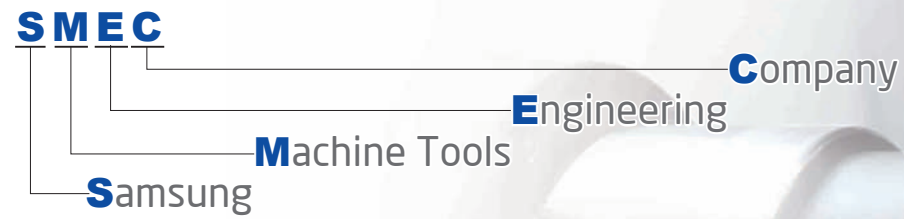

		PL 2000A PL 2000AM	PL 2000B PL 2000BM
Swing Over Bed	mm	570	570
Max. Machining Length	mm	307 291	271 262
Chuck Size	inch	6"	8"
Bore Capacity	mm	61	76
Spindle Speed	rpm	6,000	4,500
Motor (Cont./Max)	kW	11/18.5	11/18.5
Travel (X/Z)	mm	175/350	175/350
No. of Tools	EA	10[12] 12(BMT45)	10[12] 12(BMT45)

[]:Option

PL 2000 series

Compact Roller LM Guide Type,
Economical 6~8" Small Turning Center

- 45 degree slant bed with torque tubing for heavy duty turning
- significantly reduced non-cutting time for efficient turning
- low center of gravity for vibration dampening and minimized thermal growth for high rigidity



Machine Design

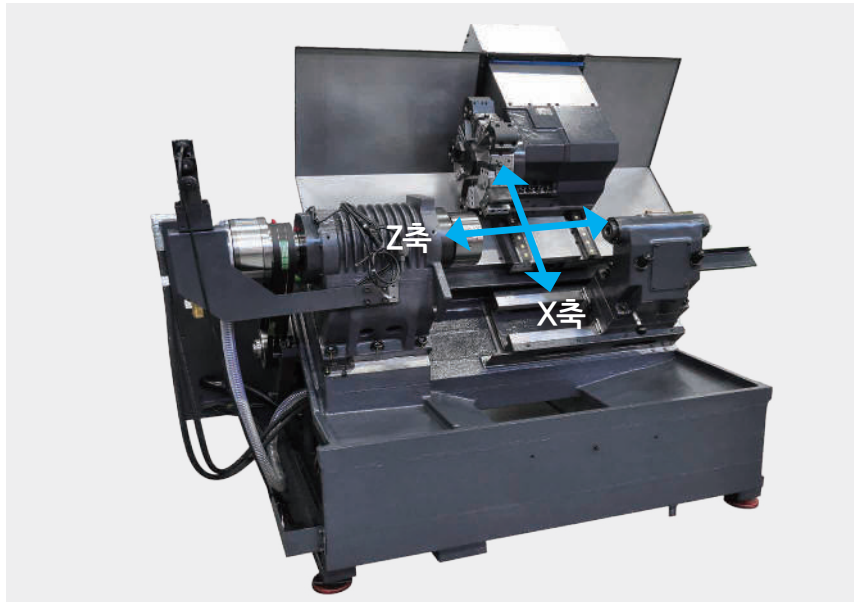

All feed axes use environmentally friendly grease lubrication with roller LM guides for high rigidity.

High Reliability, High Rigidity

Torque Tube Rib casting and wide guideways ensure high precision and durability by dampening torsion and vibration, even during heavy duty machining

45 degree slant bed supports heavy duty machining

Surface contact area increased by **60%** from the previous model to increase stiffness.

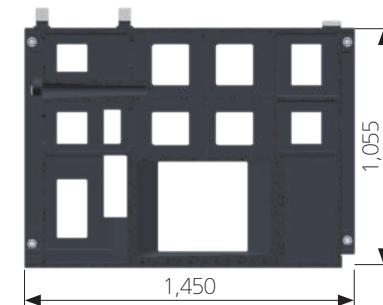

Model	Chuck Size	Stroke(mm)		Rapid Traverse(m/min)	
		X-axis	Z-axis	X-axis	Z-axis
PL 2000A	6"	175	350	36	36
PL 2000AM	6"	175	350	36	36
PL 2000B	8"	175	350	36	36
PL 2000BM	8"	175	350	36	36

Work Range

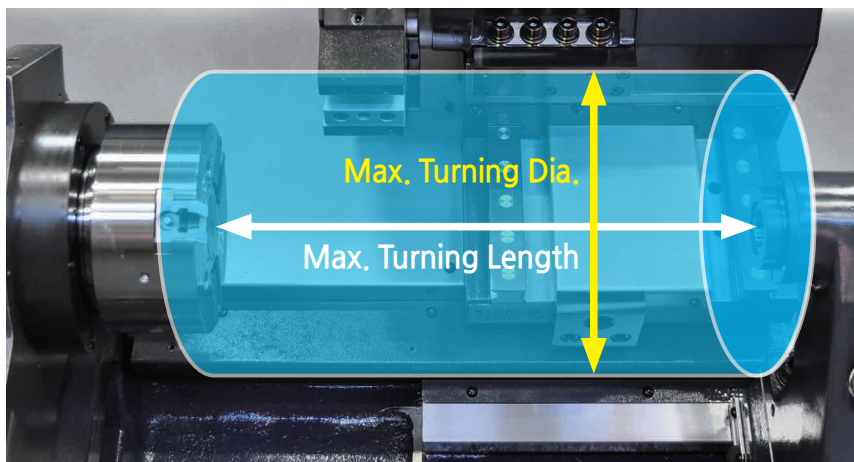

Best-in-class work range.

Max. Turning Dia.
Ø310 mm (PL 2000A/B)

Max. Turning Length
307 mm (PL 2000A)

Model	Unit	Max. Turning Dia.	Max. Turning Length	Bar Working Dia.
PL 2000A	mm	Ø310	307	51
PL 2000AM	mm	Ø270	291	51
PL 2000B	mm	Ø310	270.5	67
PL 2000BM	mm	Ø270	261.6	67

Spindle

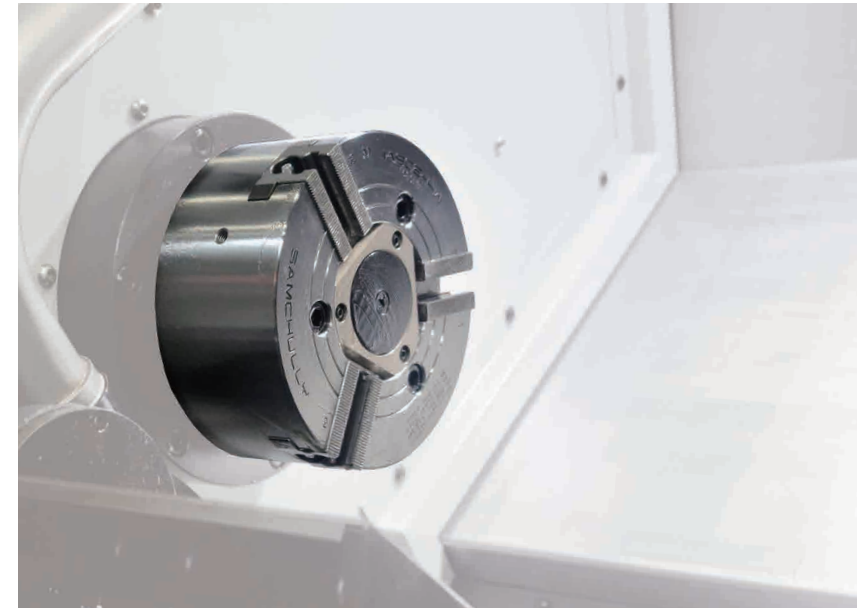

Improved productivity with high power / torque motor supporting high precision and heavy duty cutting.

Spindle Speed
6000 rpm (6inch)

Max. Torque
211 N·m(8inch)

Model	Std Chuck Size	Spindle speed rpm	Spindle Power (Cont./Max) kW	Spindle Torque (Cont./Max) N·m
PL 2000A	6"	6,000	11/18.5	53/118
PL 2000AM	6"	6,000	11/18.5	53/118
PL 2000B	8"	4,500	11/18.5	94/211
PL 2000BM	8"	4,500	11/18.5	94/211

Swing over the bed : **570** mm
Swing over the cross slide : **310** mm
Max. Turning dia. : **310** mm
Max. Bar working dia : **51** mm

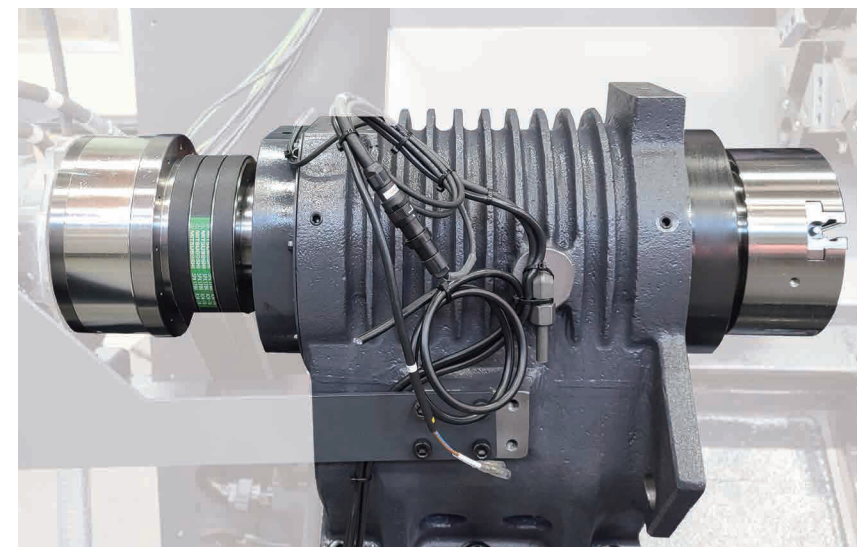

Radiator Fin Design to Reduce Thermal Growth

Radiator Fin design minimizes thermal growth of the spindle, preventing changes in precision due to increasing temperature. Also, the symmetrical spindle structure minimizes thermal growth.

3 high precision Angular Ball Bearings are placed at the front while a set of Double Cylinder Roller Bearings are placed at the rear of the spindle to ensure high precision, high speed cutting.

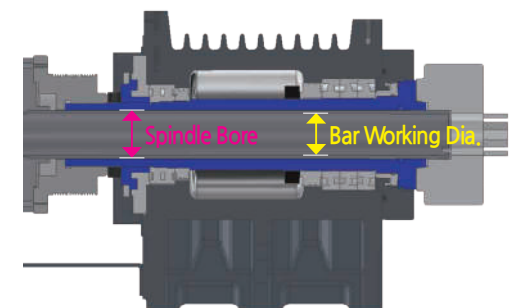

Category	Unit	PL 2000A / AM	PL 2000B / BM
Spindle Bore	mm	Ø61	Ø76
Bar Working Dia.	mm	Ø51	Ø67
Spindle Nose	ASA	A2-5	A2-6

Turret

HIGH SPEED, HEAVY DUTY SERVO TURRET

PL 2000A/B : 10 Stations (□25×25, Ø40)

12 Stations(Opt.) (□20×20, Ø32)

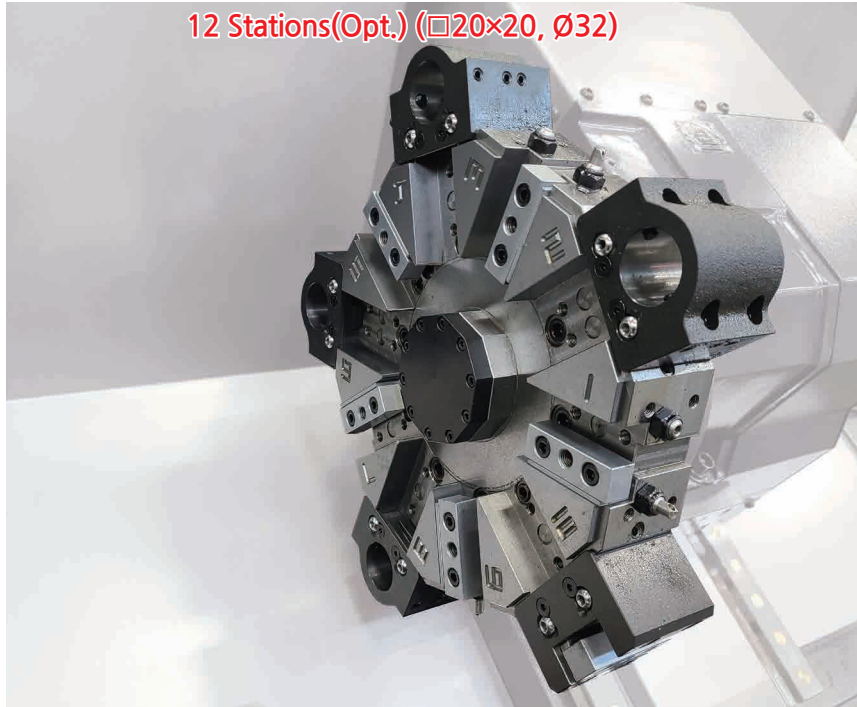

Minimized non-cutting time with high-speed indexing turret with 0.2 second indexing per station.

Tool selection is made with turret indexing time of 0.2 seconds per station made possible through the High Power Servo Index Motor using the Non Stop Random Index Method. The Ø145mm large diameter Curvic Coupling enhances the clamping power and indexing accuracy.

Turret Indexing Time

0.2 sec

No. of Tool Stations

10 station

12 station(Opt.)

HIGH SPEED MILL TURRET (BMT45)

PL 2000AM/BM : 12 Stations (□20×20, Ø32)

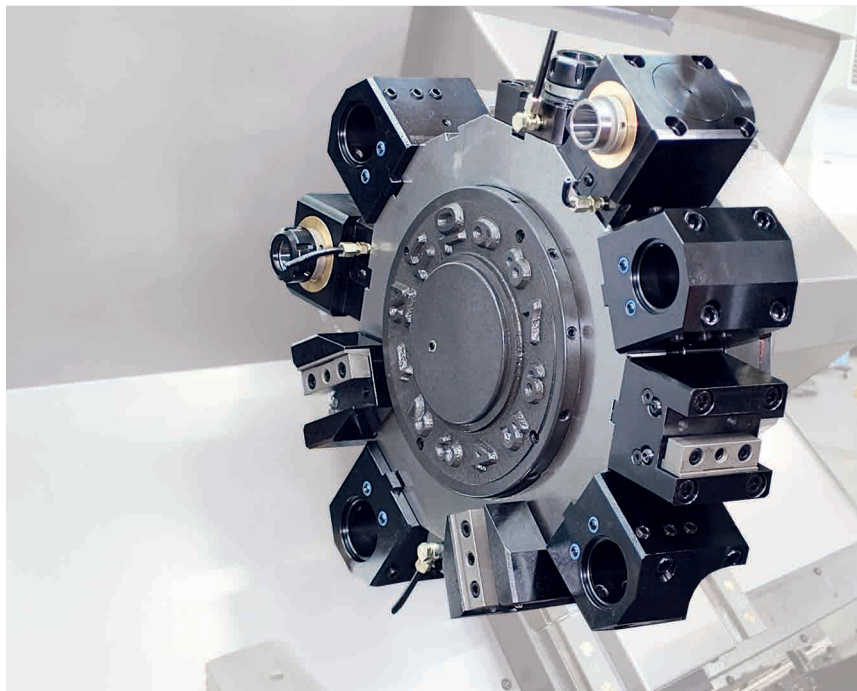

BMT Milling Turret (AM/BM Type)

The 12 station BMT turret with the largest in class Curvic Coupling and powerful clamping force, is capable of accepting rotary tool on every tool position and supports a variety of machining operations with a single set-up.

The best in class tool holders ensure high rigidity, high precision machining and with Non Stop turret indexing in either direction minimizes the turret index time down to 0.15 seconds per station.

Turret Indexing Time

0.15 sec

No. of Tool Stations

12 station

Spindle Drive

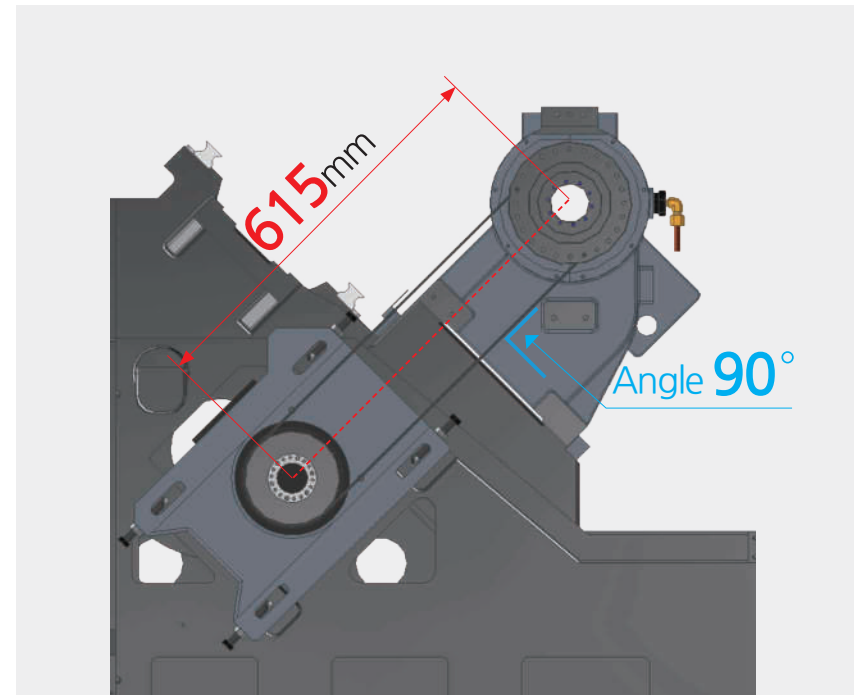

- Distance between spindle and spindle motor has been reduced compared to previous models.
- The internalized spindle motor design minimizes the required floor space.
- Thermal growth is minimized with TENSION in the orthogonal direction.

Angle **90°**

Distance between spindle and moto

615mm

Distance compared to previous model

12% shorter

Tailstock Opt.



Used to maintain high precision during heavy duty cutting, the tailstock may be traversed using the MPG handle or manually.

Tailstock Stroke

350mm

Quill Stroke

80mm

Quill Taper

MT4

PL 2000 Series

CNC TURNING CENTER

Machine Features

- SLIDE WAY : ROLLER LM GUIDE(SLIDE COVER ADDED)
- Improved chip discharge

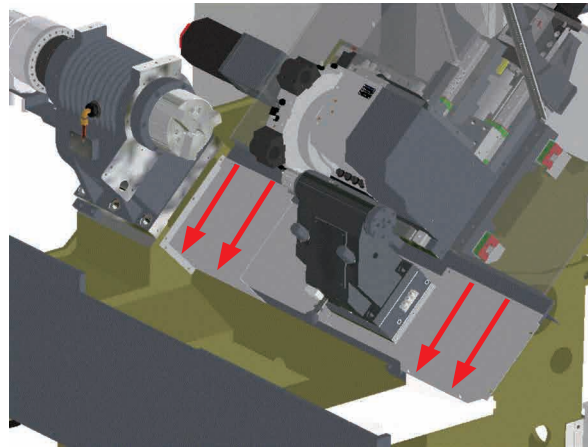

Easy Chip Discharge

The 45 degree slant bed allows easy chip discharge and easy tool replacement and inspection.

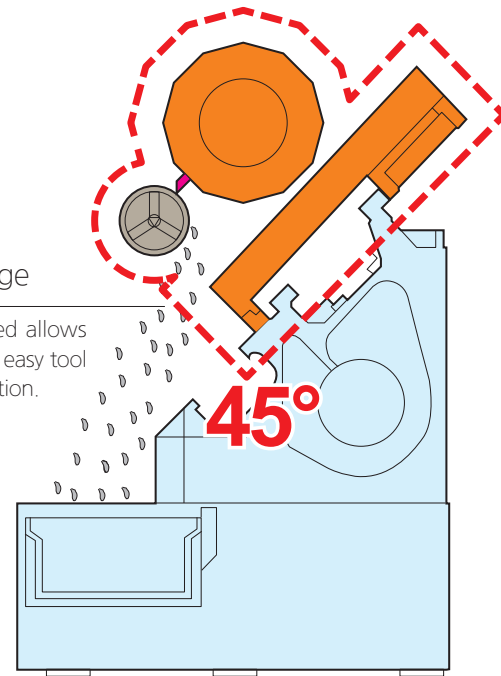

Efficient Space Usage

- Minimized installation footprint design
- Effective chip discharge
- Centralized OP panel for operator convenience
- More units can be installed and operated in the amount of space.

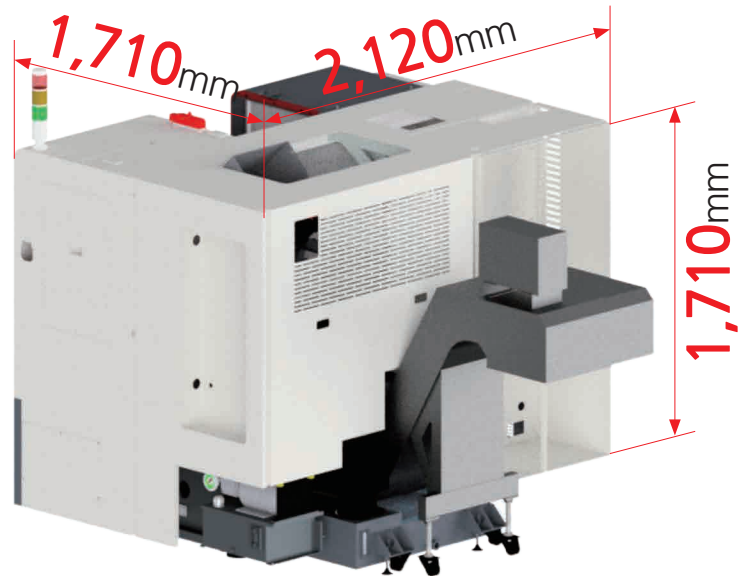

"Machine length reduced by **25%** compared to previous model"



Automatic Lubrication Dispenser

Using a system that provides the correct amount of lubrication to all necessary points, it maintains the accuracy of the feed systems and extends the lifetime of each component.

If there is a problem in the lubrication line or there is insufficient lubrication, an alarm message is displayed and the machine automatically stops to ensure safe operation.

Machine Features



Feed system with pretension and both ends fixed.

All feed axes ballscrews are fixed on both ends with pretension. Feed axes are driven by large-diameter high-precision ballscrews and are supported on both ends with high-precision P4 class angular bearings.

Rapid Traverse(X/Z)

36 m/min

- LED worklight location
- Worklight glare prevention

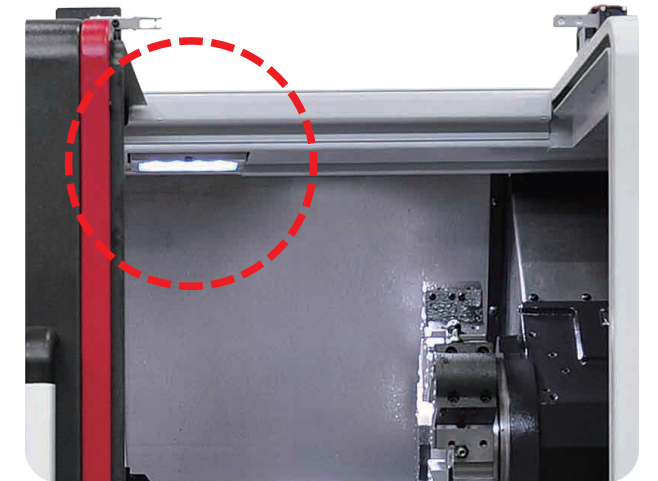

Flexible Chip Discharge

The same chip conveyor and coolant tank may be used either as rear-discharge or side-discharge for customer convenience.

Tank Capacity

140 ℓ

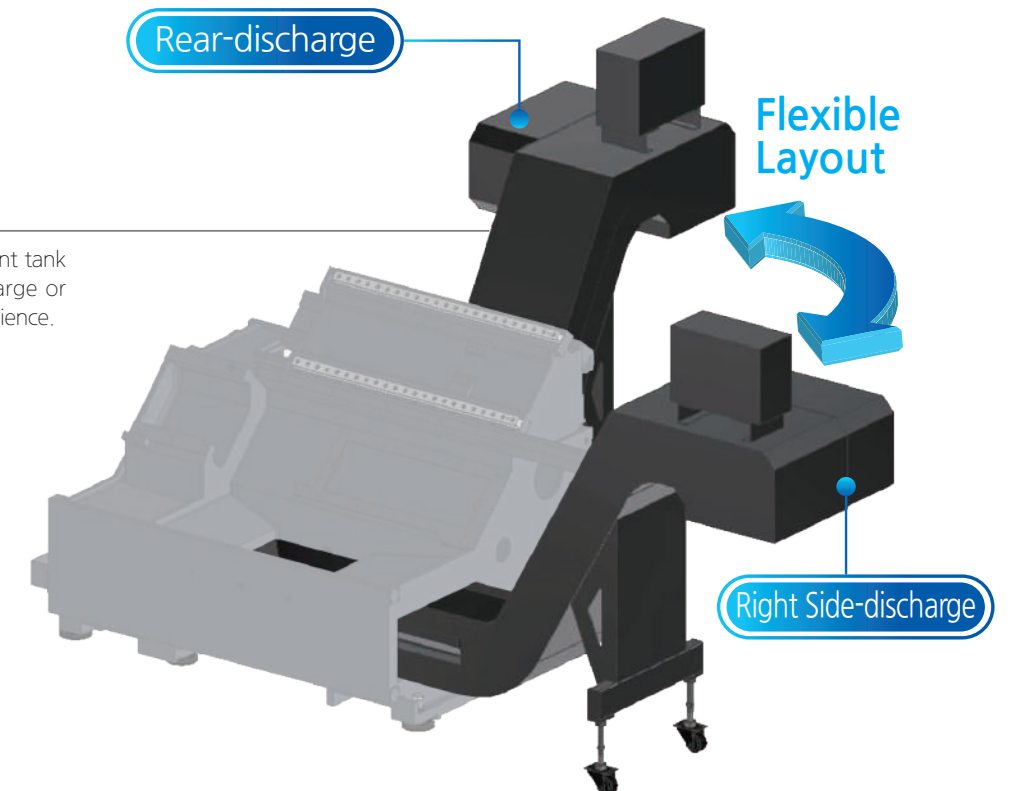

SMEC FANUC i series



PL 2000

- 10.4" LCD color display
- Part Program Size 2Mbyte
- High quality OP Panel design
- SMEC Custom S/W

SMEC Customer S/W accessible via MDI's or using the button in the OP Panel



PL 2000M

- 10.4" LCD color display
- Part Program Size 2Mbyte
- High quality OP Panel design
- SMEC Custom S/W
- Conversational programming
- Manual guide i

SMEC Customer S/W accessible via MDI's **S1** or using the button in the OP Panel

CUSTOM : Enhancing customer convenience and productivity by supporting various functions such as tool management and peripheral device setting.

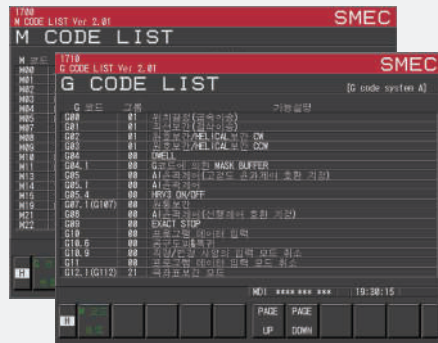

M/G Code Check

Convenience software allowing operator to read the M/G code directly from the machine

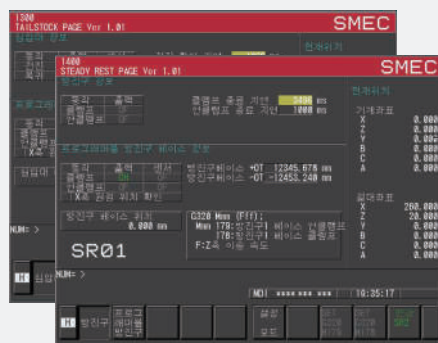

Simplified tailstock setting.

Easily configure various functions such as tailstock stroke limit, home position setting and signal check.

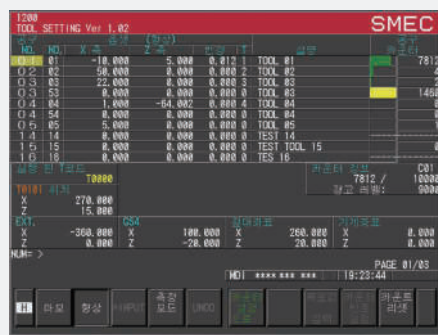

Function to simultaneously display needed tools and offsets and configured counters

Tool information and setting management mode



Check detailed PMc alarm messages

Convenient operation and maintenance when PMc alarms are generated using the detailed descriptions for cause and release method



Life counters per T Code

Cutting Performance

◆ O.D Cutting

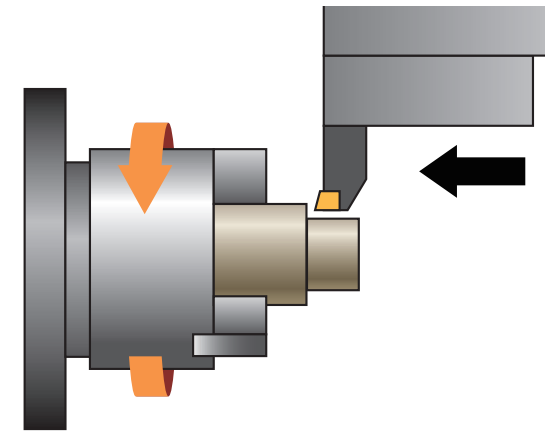

Cutting Dia.	mm	Ø45
Cutting Depth	mm	4.5
Cutting Speed	m/min	212
Spindle Speed	rpm	1,500
Feedrate	mm/rev	0.45
Chip Removal Rate	cc/min	429

◆ U-Drill Cutting

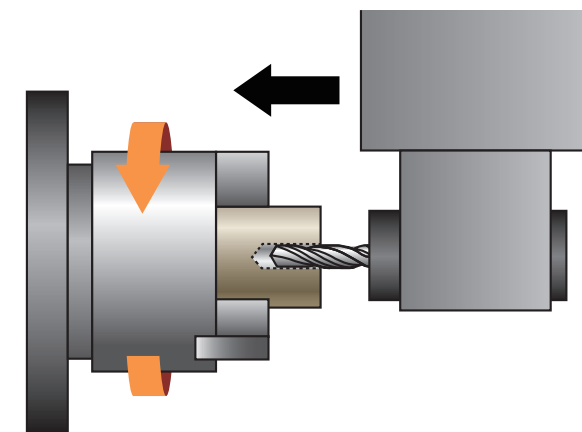

U-Drill Dia.	mm	Ø70
Cutting Depth	mm	70
Cutting Speed	m/min	180
Spindle Speed	rpm	1,500
Feedrate	mm/rev	0.23
Chip Removal Rate	cc/min	388

PL 2000 Series

CNC TURNING CENTER

Standard / Optional Specifications

Various optional features are available for customer-specific work environments.

● : Standard ○ : Optional △ : To be discussed X : Not applicable

Category	Description	PL 2000A/B	PL 2000AM/BM	Category	Description	PL 2000A/B	PL 2000AM/BM
Spindle	3 jaw open-center chuck	●	●	Chip Removal	Coolant tank 140L	●	●
	3 jaw closed-center chuck	○	○		Chip conveyor (Hinge / Scraper / Screw) Right-side	○	○
	Soft jaw (3set)	●	●		Chip conveyor (Hinge / Scraper / Screw) Rear	○	○
	Hard jaw (1set)	○	○		Special chip conveyor (Drum Filter)	△	△
	Chuck clamp footswitch	●	●	Chip bucket Standard 380L	○	○	
	Dual pressure chucking	○	○	Safety Features	Door interlock	●	●
	C-axis control (0.001")	X	●		Backspin torque limiter(BST)	X	X
	Chuck clamp confirmation	●	●		Torque limiter	X	X
Chuck dual footswitch	○	○	Full splash guard		●	●	
			Chuck hyd. pressure interlock		X	X	
Tool Holder	Tool holder	●	●	Electrical	3 step patrol lamp and buzzer	●	●
	Rotary holder type BMT	X	●		Lamp for electrical cabinet	X	X
	Rotary holder (Axial) Collet-type, 2EA	X	●		Remote MPG	X	X
	Rotary holder (Radial) Collet-type, 2EA	X	●		Work counter Digital	△	△
	Rotary holder (Axial) Adapter-type	X	○		Total counter Digital	△	△
	Rotary holder (Radial) Adapter-type	X	○		Tool counter Digital	△	△
	Boring bar sleeve (same as U-drill holder sleeve)	●	●		Multi counter 6EA	△	△
	Drill socket	●	●		Multi counter 9EA	△	△
	U-drill holder	●	●		Grounded circuit breaker	△	△
	U-drill CAP	●	●		AVR(Auto Voltage Regulator)	X	X
	Angle head	○	○	Transformer 25kVA	○	○	
				Transformer 30kVA	△	△	
Tailstock & Steady Rest	Programmable Tailstock	X	X	Measurement	Auto Power Off	○	○
	Live Center (Standard with Tailstock)	○	○		Tool Presetter Manual	○	○
	High Precision Live Center	○	○		Tool Presetter Auto	○	○
	2 Step Tailstock Pressure System	○	○		Air zero measuring device TACO	△	△
	Tailstock Quill Forward/Reverse Confirmation Device	○	○		Air zero measuring device SMC	△	△
Footswitch for Tailstock	○	○	Linear scale X-axis	○	○		
			Linear scale Z-axis	○	○		
Coolant & Air Blow	Standard coolant nozzle	○	○	Environmental	Coolant level gauge (requires chip conveyor)	○	○
	Chuck coolant	○	○		Air conditioner for electrical cabinet	○	○
	Gun coolant	○	○		Dehumidifier	△	△
	TSC for chuck (for special chuck)	△	△		Oil mist collector	○	○
	Bed flushing	○	○		Oil skimmer	○	○
	Chuck air blower	○	○	MQL(Minimal Quantity Lubrication)	○	○	
	TSC for turn-mill	○	○	Automation	Auto door	○	○
	Tailstock air blower	X	X		Auto shutter (for automation solution)	○	○
	Turret tool air blower	X	X		Sub controller	△	△
	Air gun	○	○		Barfeeder interface	△	△
	Through spindle air blower (for special chuck)	○	○		External M Code 4 Pairs	△	△
					Automation interface	△	△
Coolant pump	4.5Bar	●	●	Hydraulic Supply	I/O expansion (including both IN and OUT) 16 contacts	△	△
	7Bar	○	○		I/O expansion (including both IN and OUT) 32 contacts	△	△
	10Bar	○	○		Parts catcher	○	○
	14.5Bar	○	○		Part conveyor (requires part catcher)	X	X
	20Bar	○	○		Standard hydraulic cylinder Open-center	●	●
Power coolant system (for automation solutions)	△	△	Standard hydraulic unit 35Bar / 15L	X	X		
Coolant chiller	○	○	Standard hydraulic unit 35Bar / 20L	●	●		

* For detailed information, please contact your SMEC Machine Tools representative.

Power-Torque Diagram

PL 2000A/AM

Speed
6000 rpm

Power
11/15/18.5 kW

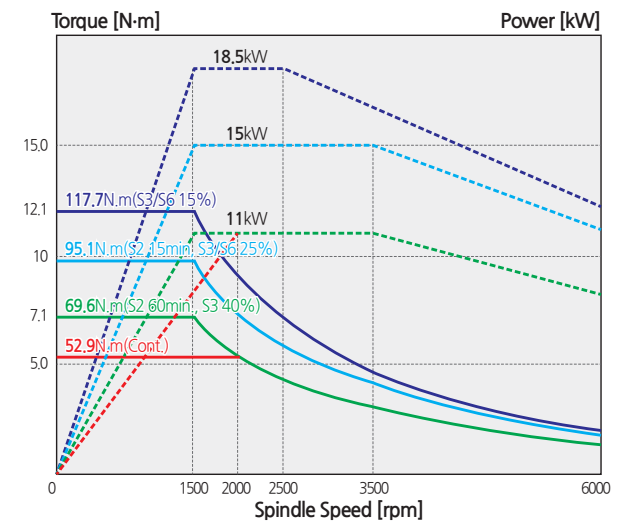

PL 2000B/BM

Speed
4500 rpm

Power
11/15/18.5 kW

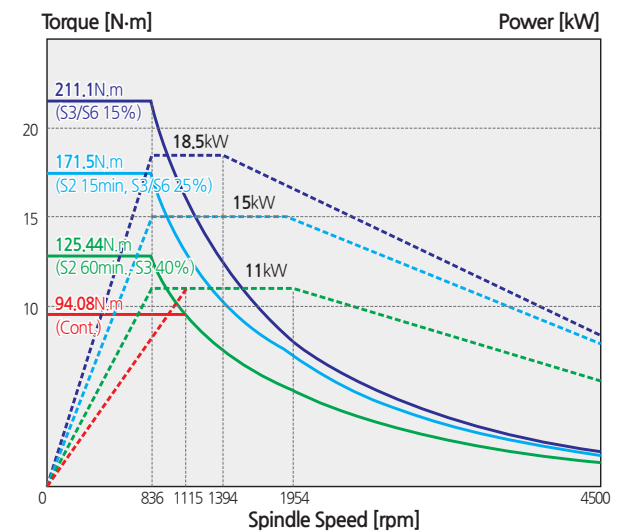

PL 2000AM/BM

Milling Motor Torque Diagram

Speed
5000 rpm

Power
2.2/3.7 kW

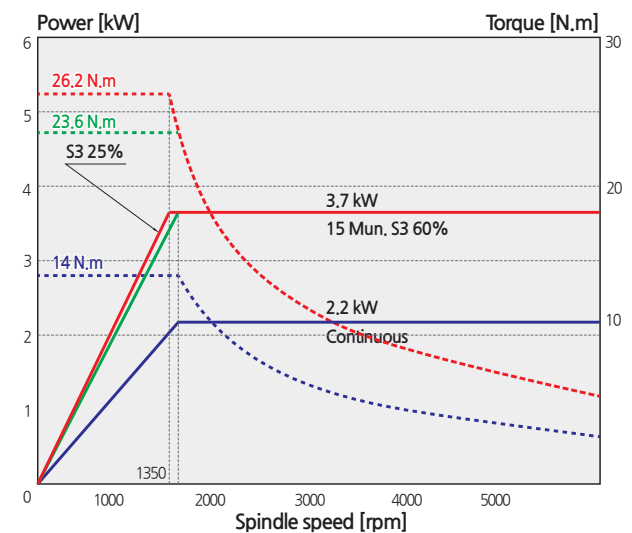

Turret Interference

PL 2000A / B

Units : mm

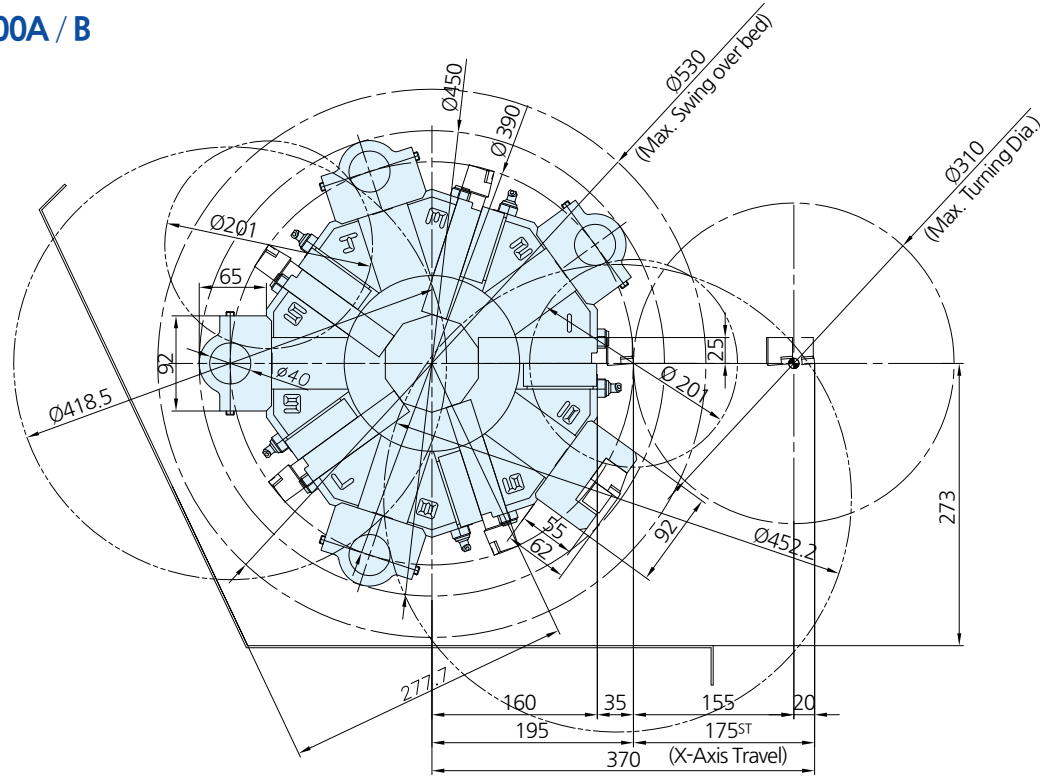

PL 2000AM / BM

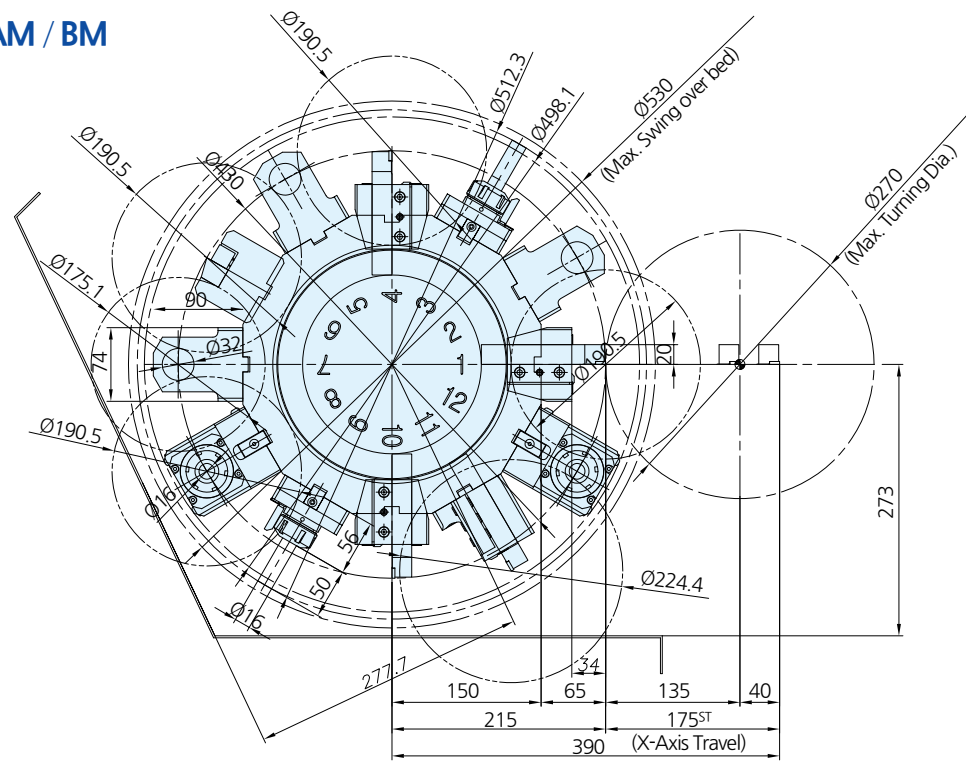

Machine Dimensions

Units : mm

Top view

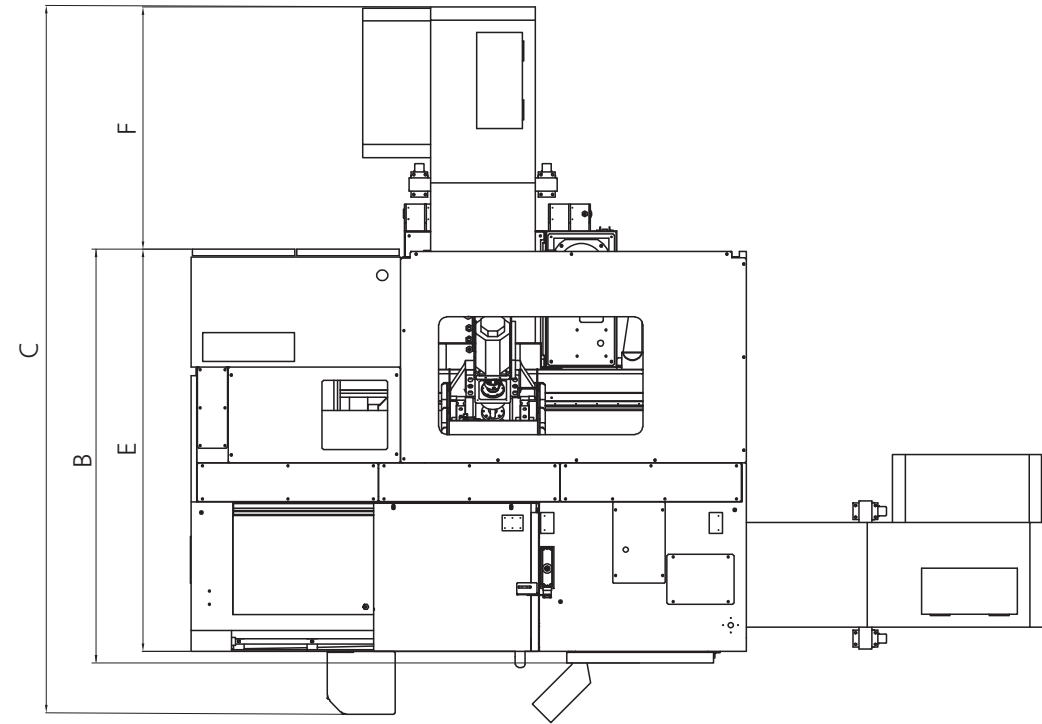

Front view

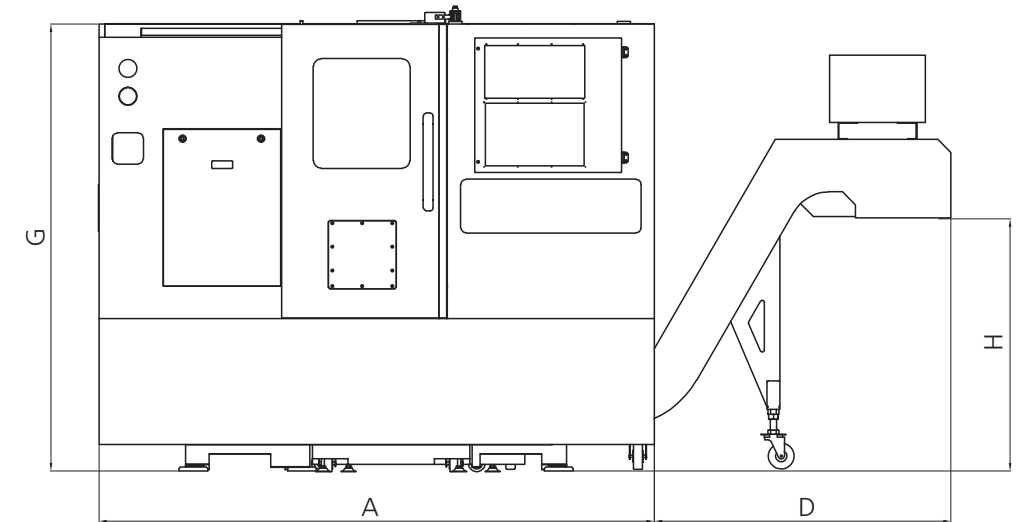

Model	A (Length)	B [Width (incl. OP Panel)]	C (Total Width)	D (Incl. Side Discharge C/C)	E (Machine Width)	F (Incl. Rear Discharge C/C)	G (Machine Height)	H (C/C Discharge Height)
PL 2000A/B	2,120	1,570	2,700	1,130	1,535	930	1,710	970
PL 2000AM/BM	2,120	1,570	2,700	1,130	1,535	930	1,710	970

Tooling System

PL 2000A / B

Unit : mm

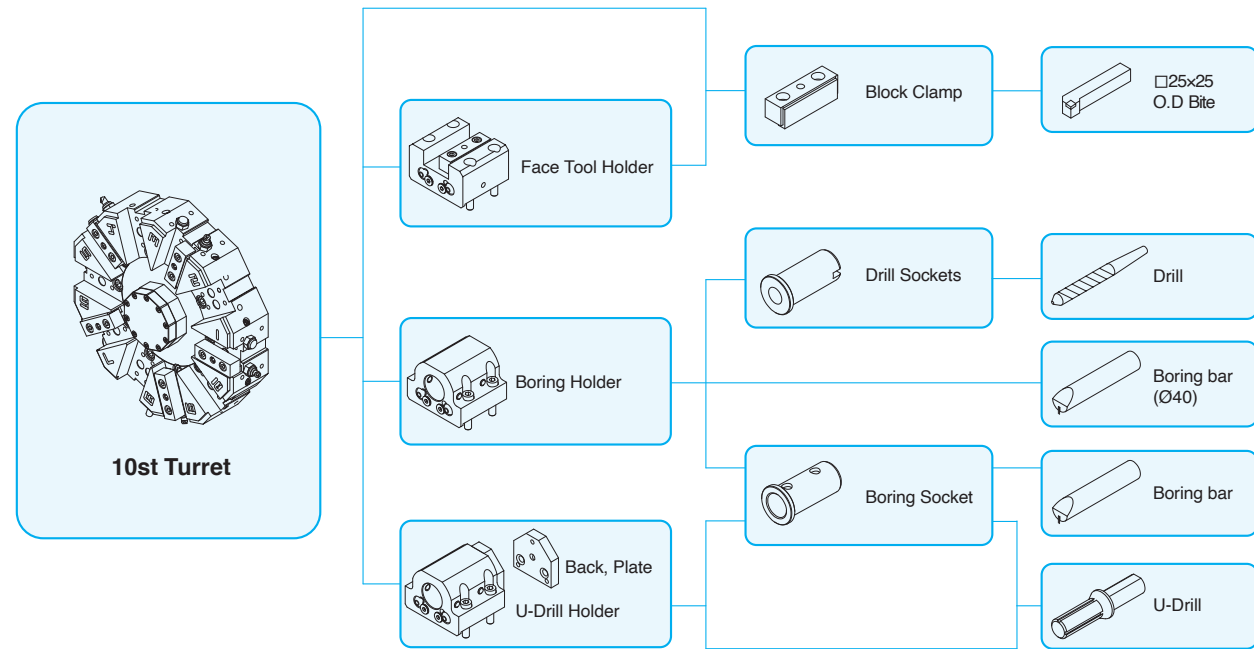

Standard Tooling(PL 2000A/B)

ITEM/ MODEL			6 Inch	8 Inch
Static Holder	Clamper		5	5
	OD Holder	Extension	-	-
	Face Holder		1	1
Boring Holder	I.D. Holder	Single (Ø40, Ø1 1/2")	3	3
	U-Drill Holder	Cap	1	1
Driven Holder	Axial Driven Holder	Standard	-	-
		T.T.C	-	-
	Radial Driven Holder	Standard	-	-
Socket	Boring	Ø8	1	1
		Ø10	1	1
		Ø12	1	1
		Ø16	1	1
		Ø20	1	1
		Ø32	1	1
	Drilling	MT1	1	1
		MT2	1	1
	ER Collet		-	-

Tooling System

PL 2000AM / BM

Unit : mm

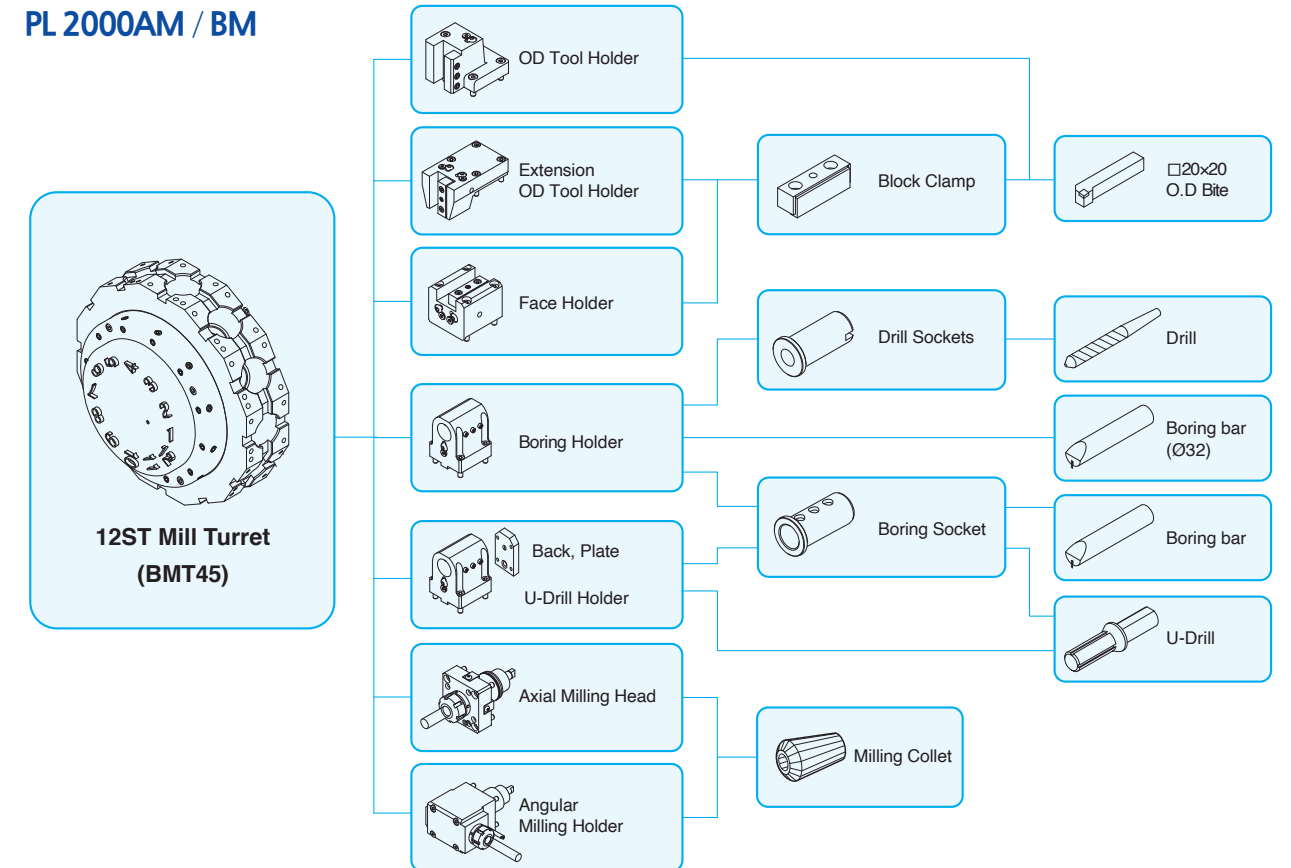

Standard Tooling(PL 2000AM/BM)

ITEM/ MODEL			6 Inch	8 Inch
Static Holder	Clamper		6	6
	OD Holder		1	1
	OD Holder	Extension	3	3
	Face Holder		1	1
Boring Holder	I.D. Holder	Single (Ø40, Ø1 1/2")	2	2
	U-Drill Holder	Cap	1	1
Driven Holder	Axial Driven Holder	Standard	2	2
		T.T.C	-	-
	Radial Driven Holder	Standard	2	2
Socket	Boring	Ø8	1	1
		Ø10	1	1
		Ø12	1	1
		Ø16	1	1
		Ø20	1	1
		Ø25	1	1
	Drilling	MT1	1	1
		MT2	1	1
	ER Collet		-	-

Work Range

PL 2000A

Unit : mm

O.D Tool

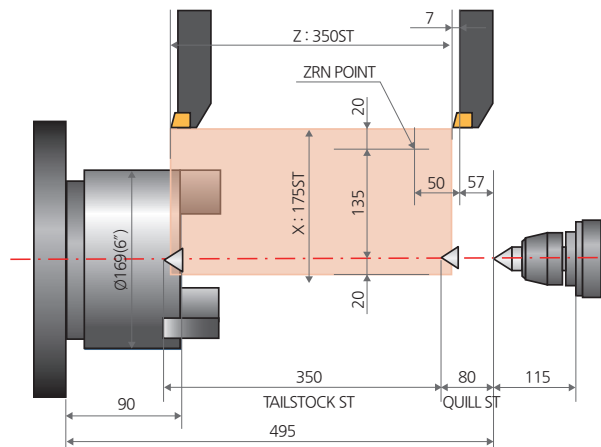

I.D Tool

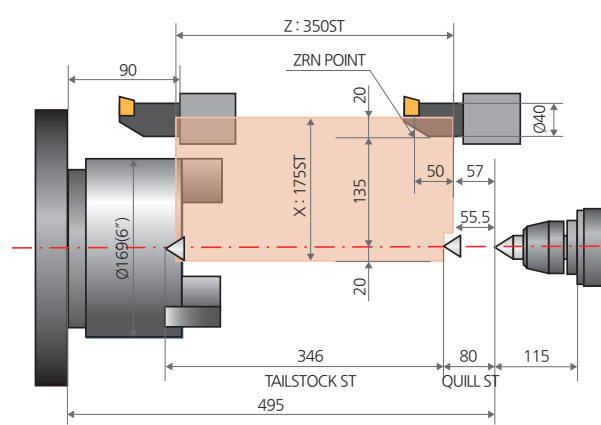

PL 2000B

O.D Tool

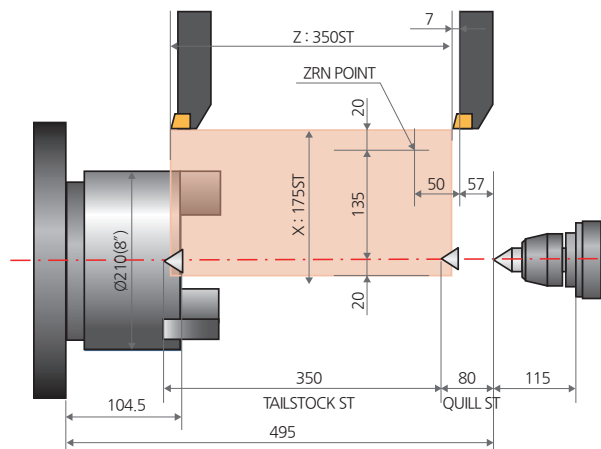

I.D Tool

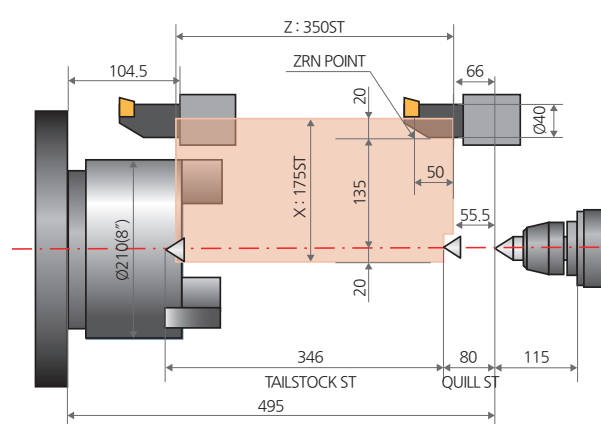

Work Range

PL 2000AM

Unit : mm

O.D Tool

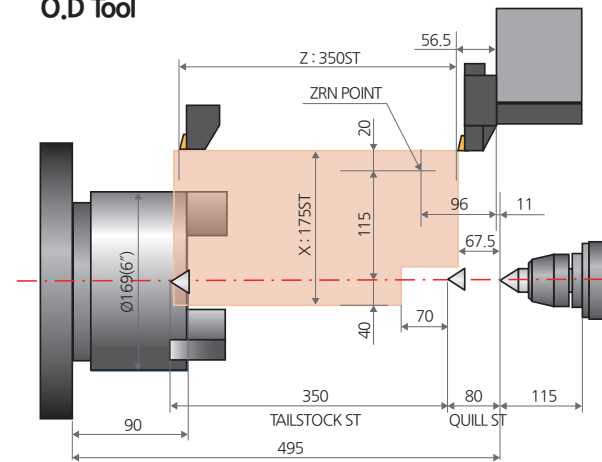

Ext O.D Tool

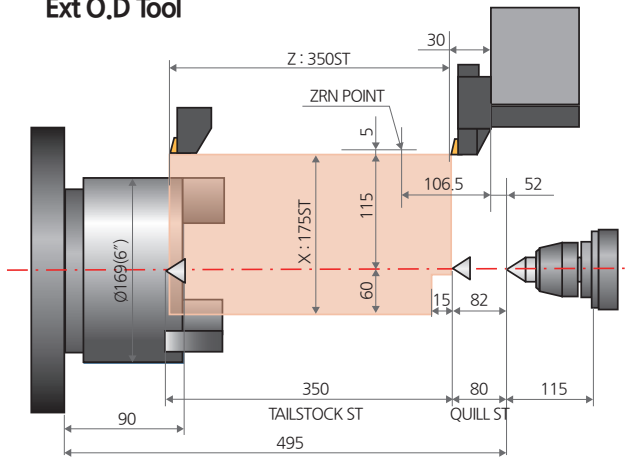

I.D Tool

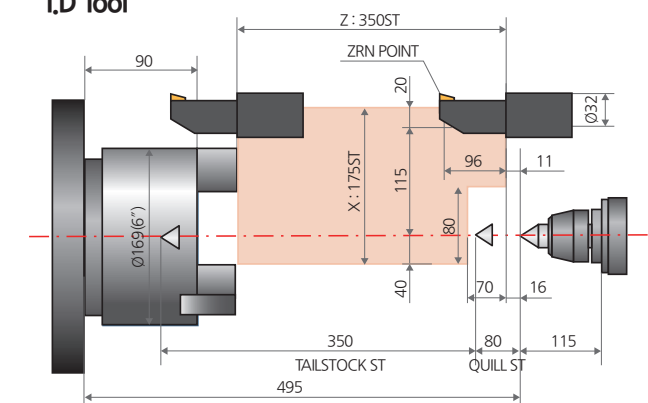

Axial milling head (ER25)

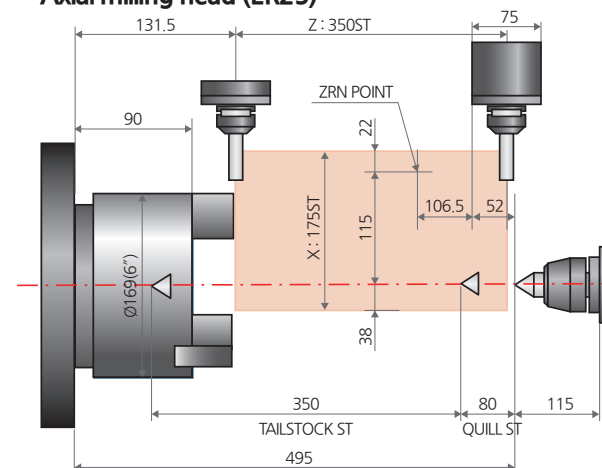

Angular milling head (ER25)

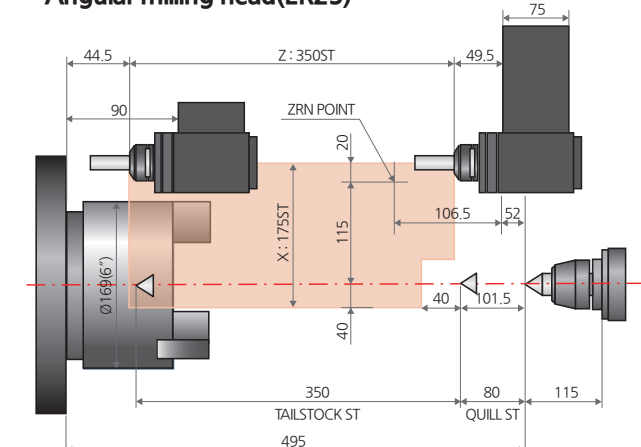

Work Range

PL 2000BM

Unit : mm

O.D Tool

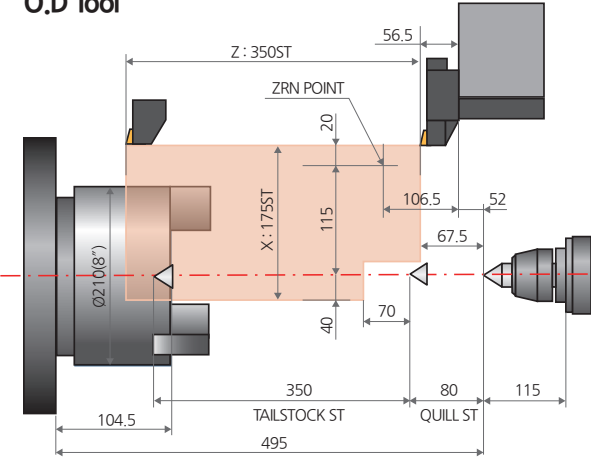

Ext O.D Tool

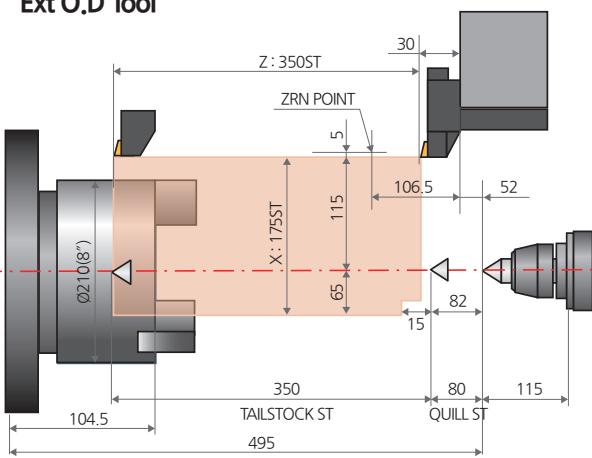

I.D Tool

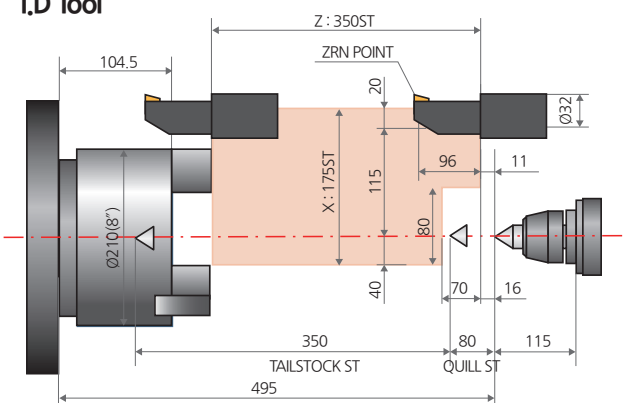

Axial milling head (ER25)

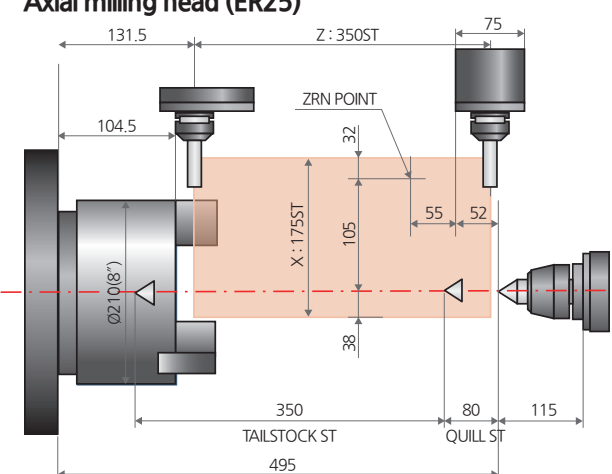

Angular milling head(ER25)

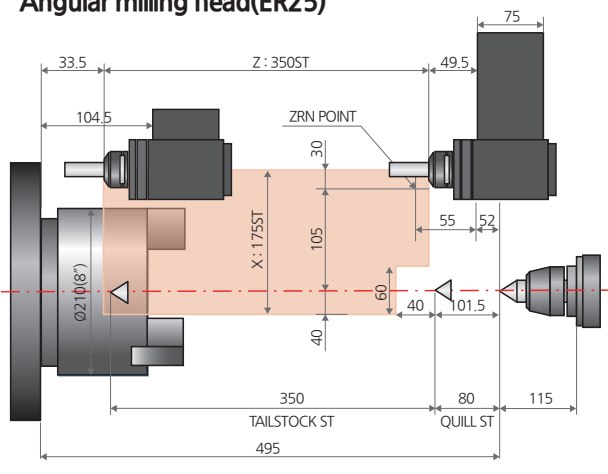

Machine Specifications

DESCRIPTION			PL 2000		PL 2000M	
			A type	B type	A type	B type
Chuck	Chuck Size	inch	6"	8"	6"	8"
	Swing over Bed	mm	570	570	570	570
Capacity	Swing over Cross-slide	mm	310	310	310	310
	Max. Turning Dia.	mm	310	310	270	270
	Max. Milling Dia.	mm	-	-	310	310
	Max. Turning Length	mm	307	270.5	291	261.6
Spindle	Spindle Speed	rpm	6,000	4,500	6,000	4,500
	Spindle Nose	ASA	A2-5	A2-6	A2-5	A2-6
	Draw Tube I.D.	mm	52	68	52	68
	Spindle Bore	mm	61	76	61	76
	Spindle Motor (Cont./Max)	kW	11/18.5	11/18.5	11/18.5	11/18.5
Travels	X-axis Stroke	mm	175	175	175	175
	Z-axis Stroke	mm	350	350	350	350
	X-axis Rapid Traverse	m/min	36	36	36	36
	Z-axis Rapid Traverse	m/min	36	36	36	36
Turret	No. of Tool Positions	ea	10	10	12(BMT45)	12(BMT45)
	Shank Size for Square Tool	mm	□25×25	□25×25	□20×20	□20×20
	Boring Bar Dia.	mm	40	40	32	32
	Indexing Time	sec	0.20	0.20	0.15	0.15
	Rotary Tool Speed	rpm	-	-	5,000	5,000
	Rotary Tool Motor (Cont./Max)	kW	-	-	2.2/3.7	2.2/3.7
Tailstock	Quill Dia.	mm	65	65	65	65
	Quill Stroke	mm	80	80	80	80
	Tailstock Stroke	mm	350	350	350	350
	Quill Taper	MT	MT4	MT4	MT4	MT4
Machine	Size (incl. side discharge chip conveyor) L×W×H	mm	2,120(3,252) × 1,710 × 1,710		2,120(3,252) × 1,710 × 1,710	
	Size (incl. rear discharge chip conveyor) L×W×H	mm	2,120 × 1,710(2,842) × 1,710		2,120 × 1,710(2,842) × 1,710	
	Weight	kg	2,850	2,940	3,100	3,190
	Coolant Pump Power	kW	1.1	1.1	1.1	1.1
	Coolant Tank Capacity	Liter	140	140	140	140
ELECTRIC POWER SUPPLY	kVAV	25/220	25/220	25/220	25/220	
CONTROLLER		FANUC Oi-TF Plus				

※Design and specifications are subject to change without notice.

[] : Option

PL 2000 Series

CNC TURNING CENTER

NC Specifications / FANUC Series



● : Standard ○ : Optional X : Not applicable

Item	0i-TF+		
	PL 2000A/B	PL 2000AM/BM	
Controlled axis	Controlled axes	X, Z	
	Max. simultaneously controlled axes	4	
	Least command increment	0.001mm / 0.0001"	
	Stored stroke check	Soft overtravel 1, 2, 3	
	Machine lock	●	
Operation functions	Pulse handle feed	X1, X10, X100	
	Dry run	●	
	Single block	●	
	Feedrate per minute	G94	
	Feedrate per revolution	G95	
	DNC operation	Ethernet, CF card	
	Retraction for rigid tapping	○	
	Interpolation functions	Linear interpolation	G01
Circular interpolation		G02, G03	
Dwell		G04	
Cylindrical interpolation		G70.1	
Skip		G31	
Nano smoothing		X	
Polar coordinate interpolation		●	
Reference position return		G28	
Reference position return check		G27	
2nd/3rd/4th reference position return		G30	
Variable lead thread cutting		●	
Thread Repair		Manual guide i 필요	
Feed function		Rapid traverse rate override	F0, 25%, 50%, 100%
		Feedrate override	0~200%
	Jog Override	●	
	AI advanced preview control	X	
	AI contour control II	OPT(200 block)	
Spindle function	Spindle orientation	●	
	Rigid tapping	M29	
	Spindle override	S0 ~ 150%	
	Arbitrary speed threading	○	
Tool functions	Tool number command	T4-Digit Tool number	
	Tool nose radius compensation	G40 ~ G42	
	Tool offset pairs	128-pairs	
	Tool geometry/wear offset	●	
	Tool length offset	●	
	Tool life management	●	
Tool path graphic display	●		

NC Specifications / FANUC Series



● : Standard ○ : Optional X : Not applicable

Item	0i-TF+	
	PL 2000A/B	PL 2000AM/BM
Program input	Absolute/incremental programming	G90/G91
	Multiple repetitive cycle	●
	Multiple repetitive cycle II	●
	Canned cycles	●
	Canned cycle for drilling	●
	Decimal point programming	●
	Inch/metric conversion	G20 / G21
	Program restart	●
	Sub program call	●
	Max. programmable dimension	±99999.999mm/±9999.9999"
	M function	3 digit
	Custom macro	●
	Addition of custom macro common variables	#100~#199, #500~#999
	Direct drawing dimension programming	●
	Programmable data input	G10
	Tape code	ISO / EIA
	Optional block skip	●
	Workpiece coordinate system	G52 ~ G59
	Addition of workpiece coordinate system	X
	Interface function	Embedded ethernet
Fast ethernet		X
Setting and display	Alarm & Operator histor display	●
	Run hour and parts count display	●
	Display spindle & servo overload	●
	Self-diagnosis function	●
	Extended part program editing	●
	Machining condition selecting function	○
	Machining quality level adjustment	X
	Display screen	10.4" color LCD
	Multi-language display	25 language
Data input/output	Fast data server	X ○
	RS232C interface	●
	Memory card input/output	●
Editing operation	USB memory input/output	●
	Part program storage size	2Mbyte
	Number of registerable programs	1,000EA
	Manual guide 0i	○ X
Manual guide i	○ ●	