

NC Specifications / FANUC Series

Item	Description	
Controlled axes	Controlled axes	3-axis(X,Y,Z)
	Max. simultaneously controlled axes	Positioning(G00) / Linear Interpolation(G01) Circular Interpolation(G02, G03)
	Least input increment	0.001mm / 0.0001"
Spindle function	Spindle speed control	S5 (5 Digit)
	Spindle speed override	0~120%
	Spindle orientation	M19
Feed function	Feedrate override (10% increase)	0~150%
	Dwell	G04
	Reference position return	G27, G28
	Manual pulse generator	0.001/0.01/0.1mm
	Dry run	F0(Fine Feed), 25/50/100%
	Rapid traverse override	F0(Fine Feed), 25/50/100%
Tool function	Tool number command	T2 (2 Digit)
	Tool nose radius compensation	G40 ~ G42
	Tool offset pairs	128EA
	Tool geometry / wear offset	GEOMETRY & WEAR DATA
Programming function	Canned cycle	G70~G72, G74~G76
	Decimal point input	Able to input up to decimal point
	SUB program	4 phase
	Work coordinate system	G52~G59
	Max program dimension	±99999.999mm
Tape Functions	M function	M3 (3 digit)
	Input code	ISO/EIA auto recognition
	I/O interface	RS232C
	Program storage space	1280M(512kb)
	Number of stored programs	400ea
Other features	Display unit / MDI	10.4" color LCD / Soft input type MDI
	Synchronized tapping	Rigid tapping function
	Background editing	Program saving / editing during automatic operation
	Backlash compensation	Pitch error offset compensation for each axis
	Search function	Sequence / program number search
	Safety function	Emergency stop / overtravel
	Program test function	Machine Lock / Single Block
	Control function	Memory / MDI / Manual
	Mirror image	
	Run hour and parts count display	
	Custom macro	#100 ~ #199, #500 ~ #999



SMEC Co., Ltd.
157-10, Goldenroot-ro, Juchon-myeon,
Gimhae-si, Gyeongsangnam-do, Korea
Tel +82 55 340 4800
Fax +82 55 340 4740



www.esmec.com



https://www.youtube.com/c/smecmachinetools

SMEC
Smart One,
Global One

SMEC

SL 3500Y series

Y-AXIS HORIZONTAL TURNING CENTER



- 1988 - Started as Samsung Heavy Industries Machine Tools Business
- 1989 - Horizontal and vertical machining center technology partnership with OKK Japan
- 1991 - Turning center and vertical machining center technology partnership with Mori Seiki
- 1996 - 5-sided processing center technology partnership with Toshiba
- 1999 - Spun out from Samsung Aerospace Industries and established SMEC Co., Ltd

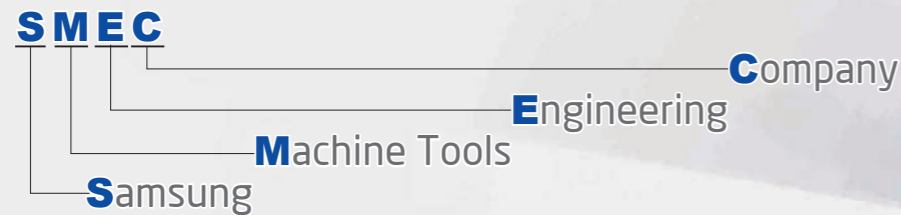

SL 3500Y/3500LY

A Type : Chuck Size 12"

B Type : Chuck Size 15"

**Strongest in class with superb structural design
Simultaneous heavy duty and precision turning**

- 30 degree torque tube type bed to support heavy duty turning
- Significantly reduced non-cutting time and efficient turning
- Low-center of gravity reducing vibration, thermal deformation and improving rigidity

High Accuracy, High Rigidity Spindle



Pin Tube Rib Design for Minimal Heat Deformation

Radiator Fan-like pin tube rib design dissipates heat generated by axis movements, maintaining minimal thermal expansion.

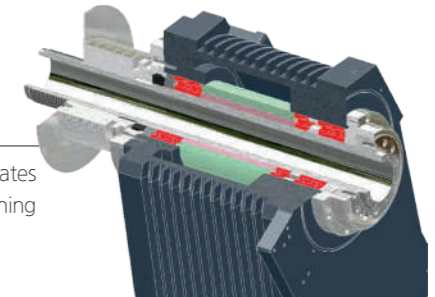

Spindle & Headstock

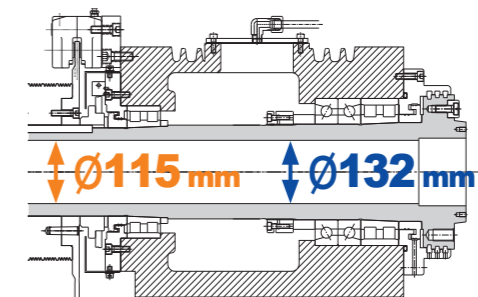

The Spindle and Headstock are machined in a temperature controlled environment and assembled in a clean room.

Spindle Speed (12" Chuck)
Max 2,500 rpm
SL 3500Y Series (A TYPE)

Spindle Speed (15" Chuck)
Max 2,000 rpm
SL 3500Y Series (B TYPE)

Spindle Power & Torque Diagram

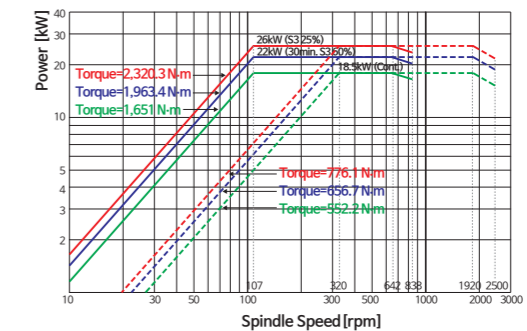

Servo Tailstock Interface

Tailstock positioning and quill thrust force are simple to set up using the specially designed servo tailstock interface.

The high speed servo driven tailstock offers high speed high precision positioning and digitally controlled thrust force settings. Quill thrust force can be set according to part length & diameter. This results in reduced down time and increased manufacturing efficiency.

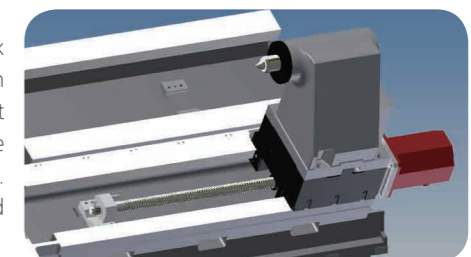

SL 3500Y/LY is a heavy-duty, ultra precision Turning Center, combined with SMEC's advanced technological features.

Spindle motor(Cont./30min)
18.5/26 kW

Spindle speed
2,500 rpm (A Type:12")
2,000 rpm (B Type:15")

Rapid traverse(X/Y/Z)
30/10/30 m/min

Max. Turning Length
780 mm (SL 3500Y)
2,125 mm (SL 3500LY)

Max. Turning Diameter
Ø430 mm

Highly Reliable and Rigid Structural Design

- One piece Meehanite casting with heavily ribbed torque tube design
- Rigid bed supports for powerful cutting
- Excellent vibration dampening and thermal displacement design

Fast Indexing and Heavy-Duty Turret Design

The 12 station heavy-duty turret features a large diameter 3-piece Curvic coupling and 7,474.5kgf(73,300N) of hydraulic clamp force. The heavy-duty design provides high rigidity for heavy cutting, unsurpassed surface finishes and long tool life.

Turret rotation, deceleration and clamp are all controlled by a reliable high torque servo motor. Turret indexing is non-stop bi-directional with a 0.15 second next station index time. Each turret station is capable of accepting both milling and turning tools.

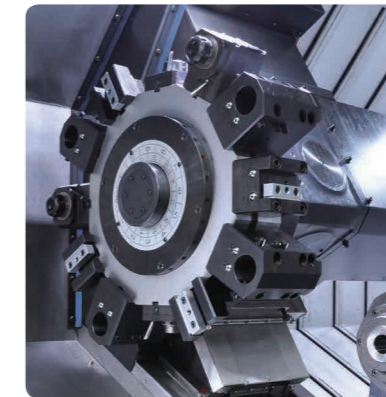
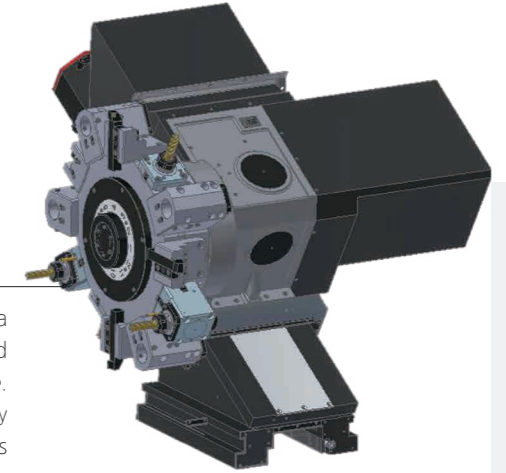

Turret Torque Diagram

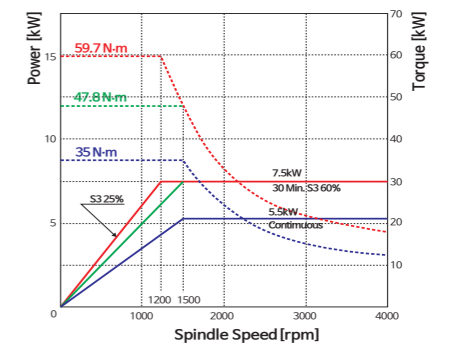

Rigid 30 degree Slant Bed

30 degree slant torque tube design bed and wide guide slide way ensure long term rigidity and machining accuracy.

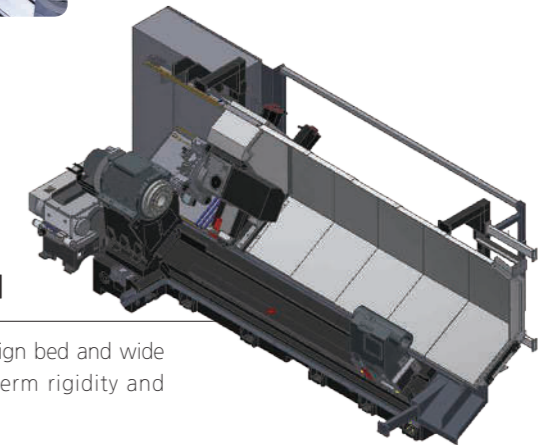

Pre-tensioned and Double Anchored Ballscrews

All axes ballscrews are pre-tensioned, heat treated and fixed by double anchors on both ends, providing ultimate rigidity and minimal thermal growth.

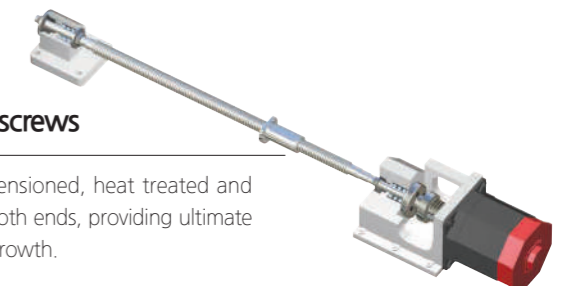

SL 3500Y series

Y-axis Horizontal Turning center



Swivel Operation Panel

Swivel operation panel of 10.4 inch color TFT LCD monitor can turn to 81 degree, providing operators with easy access to the control panel while working on the machine.

SL 3500Y series

SL 3500Y

SL 3500LY

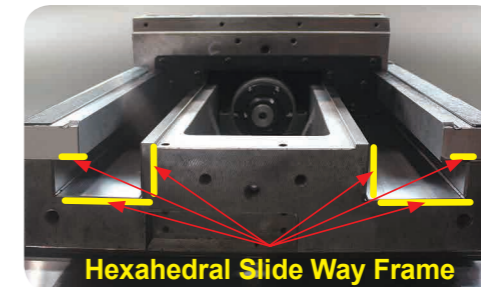
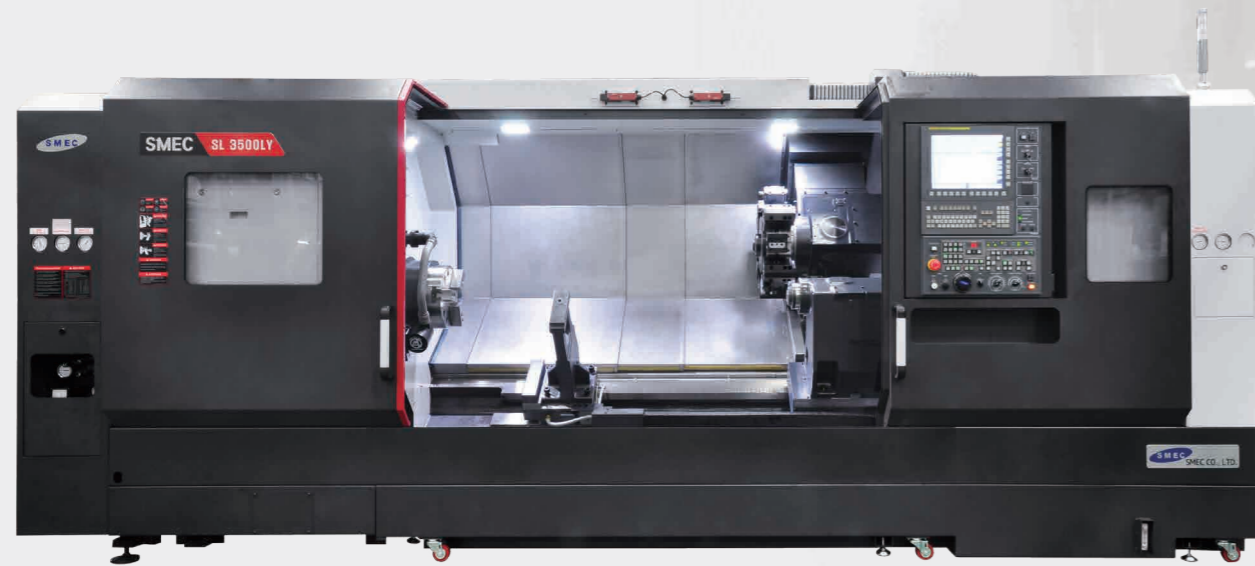

Hexahedral Slide Way Frame (X-axis)

Wide integral way is machined from the casting, induction hardened and precision ground to ensure long-term rigidity, machining accuracy and heavy-duty machining.

Y-Axis Machining

Y-axis adds integrated machining feature to a conventional turning center, providing machining capability on the workpiece that is not parallel or perpendicular to the spindle center line.

Bar machining with Y-axis control

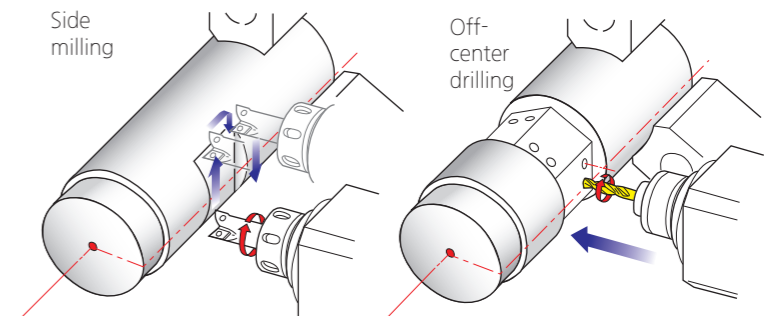

Y axis Travel
130(±65) mm

Y axis Rapid Traverse
10 m/min

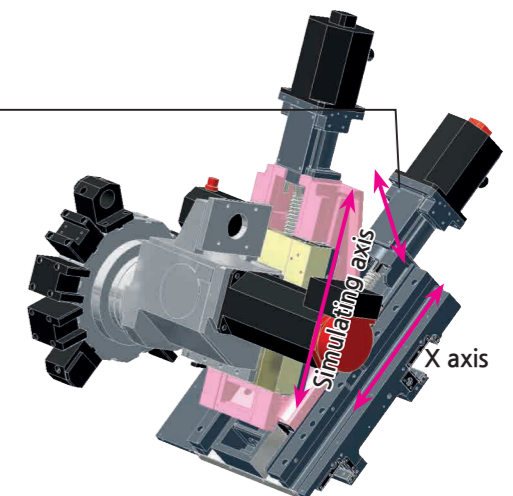

High Precision

Surface Roughness

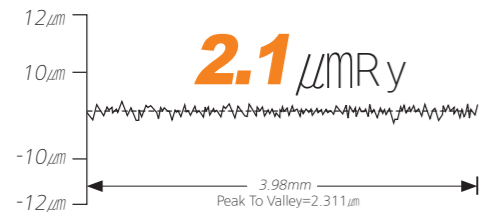

Model : SL 3500Y

Roundness

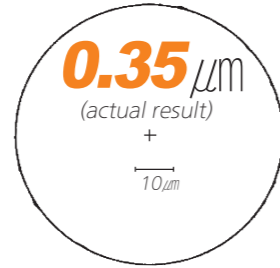

Cutting condition	
Tool	Diamond tool <nose radius 0.020 inch>
Material	AL150<Aluminum>
Cutting speed	230 m/min
Feedrate	0.05 mm/rev
Depth of cut	0.1 mm
Outer diameter	200 mm
Filter	1-50

Processing Speed

Turning Performance (material:SM45C) SL 3500Y

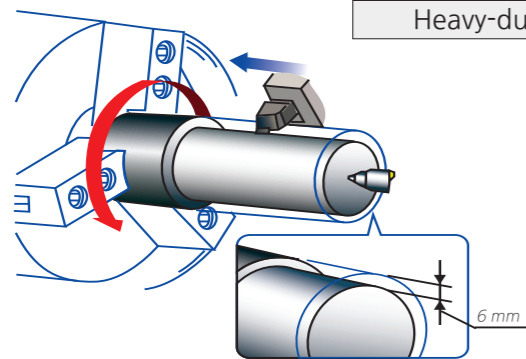

Heavy-duty cutting (O.D) <25mm×25mm qualified tool>

- Spindle speed **518 rpm**
- Cutting speed **120m/min**
- Depth of cut **6 mm <Spindle Load 40%>**
- Feedrate **0.3 mm/rev**

Optional Accessories



Tool Presetter

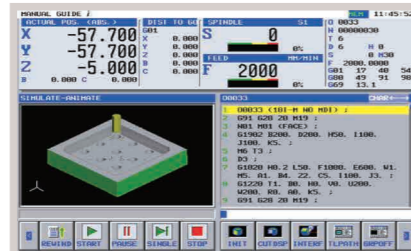

Manual Guide i

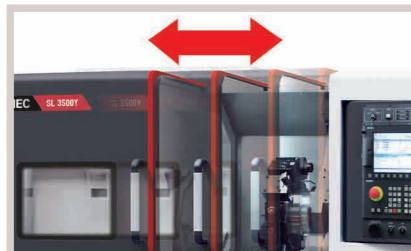

Auto Door



Chip Conveyor



Automatic Lubricator(STD.)

Tooling System

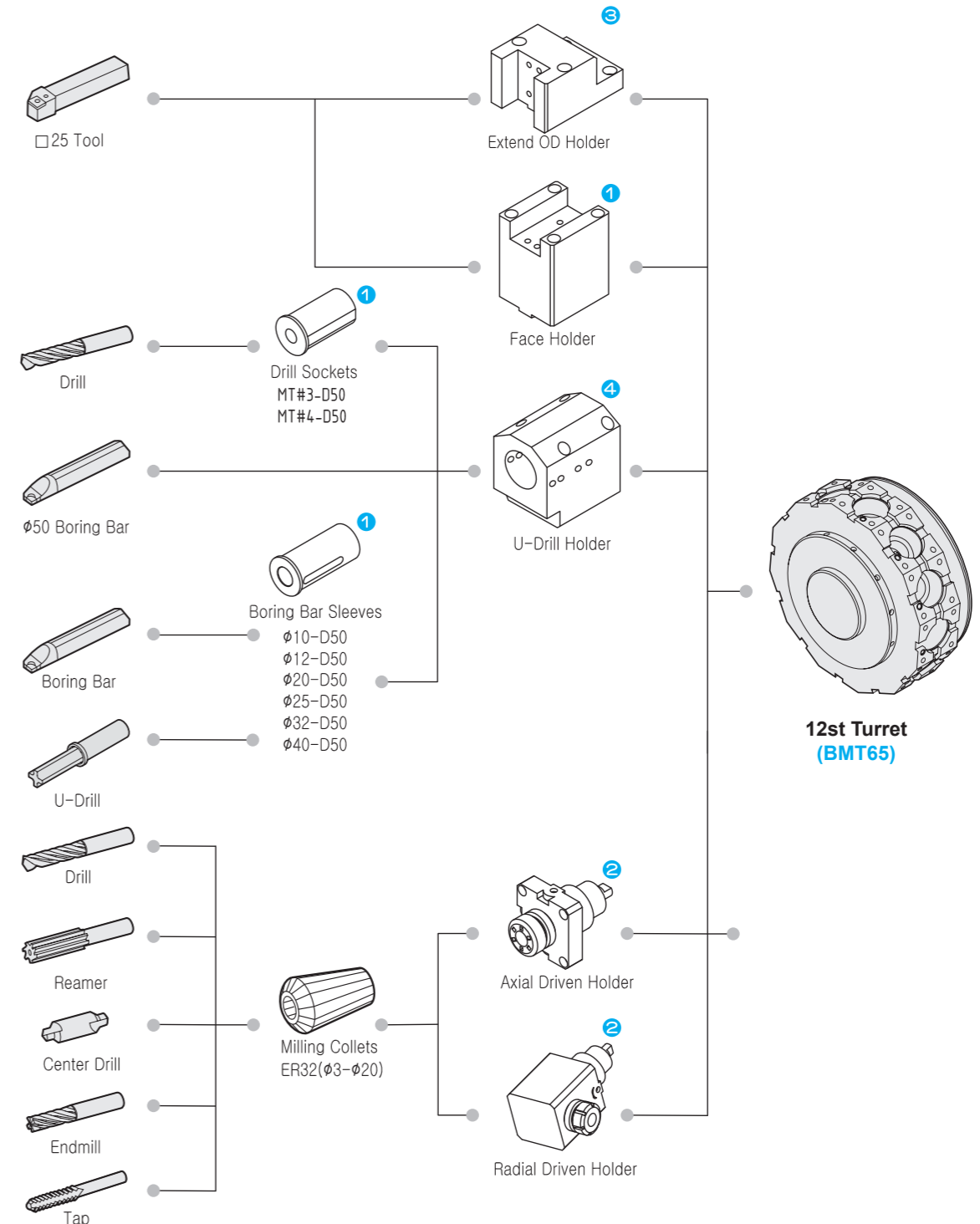

● : Standard Set Numbers

Turret Interference

Unit : mm

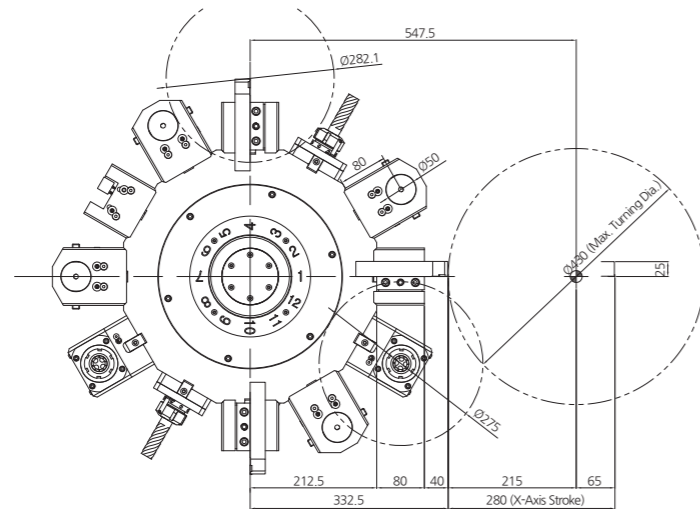

Work Range

Unit : mm

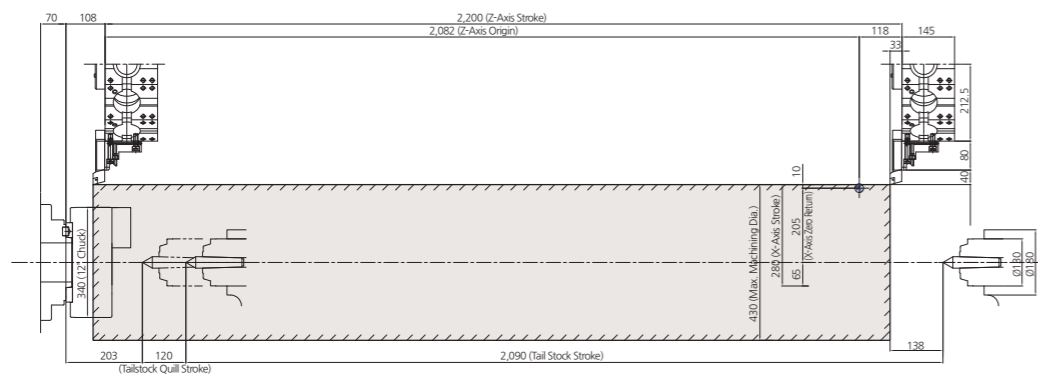

Machine Dimensions

Unit : mm

SL 3500Y(SL 3500LY)

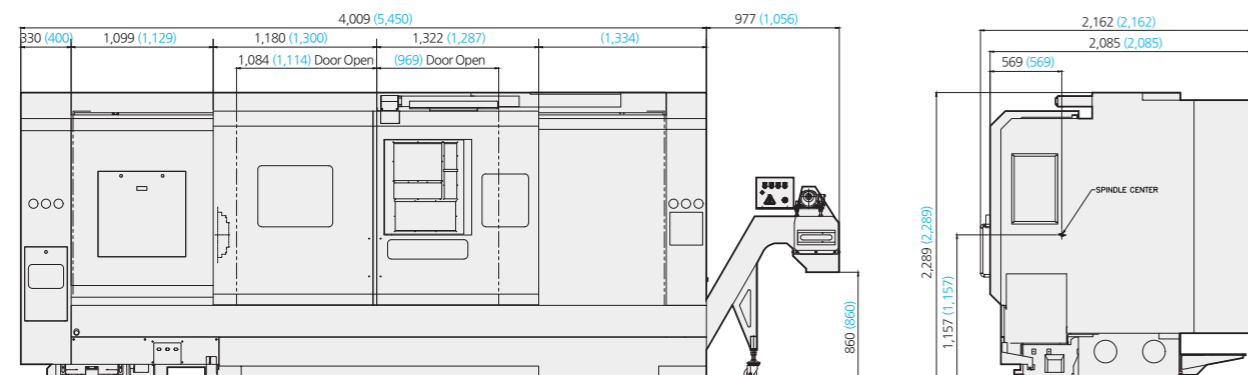

Major Specifications

DESCRIPTION			SL 3500Y		SL 3500LY	
			A type	B type	A type	B type
Chuck	Chuck size	inch	12"	15"	12"	15"
	Swing over bed	mm	850	850	850	850
Capacity	Swing over cross slide	mm	850	850	850	850
	Max. turning diameter	mm	430	430	430	430
	Max. milling diameter	mm	539	539	539	539
	Max. machining length	mm	780	780	2,125	2,125
Spindle	Spindle speed	rpm	2,500	2,000	2,500	2,000
	Spindle nose	ASA	A2-11	A2-11	A2-11	A2-11
	Draw tube ID	mm	103	117.5	103	117.5
	Spindle bore diameter	mm	115	132	115	132
	Spindle motor (Cont./Max)	kW	18.5/26	18.5/26	18.5/26	18.5/26
Travels	X-axis travel	mm	280	280	280	280
	Y-axis travel	mm	130 (±65)	130 (±65)	130 (±65)	130 (±65)
	Z-axis travel	mm	830	830	2,200	2,200
	X-axis Rapid traverse rate	m/min	30	30	30	30
	Y-axis Rapid traverse rate	m/min	10	10	10	10
	Z-axis Rapid traverse rate	m/min	30	30	30	30
Turret	Number of tool stations	ea	12[24] (BMT65)	12[24] (BMT65)	12[24] (BMT65)	12[24] (BMT65)
	Turning tool shank size	mm	25	25	25	25
	Boring bar diameter	mm	50	50	50	50
	Turret index time(next station swivel time)	sec	0.20	0.20	0.20	0.20
	Rotary tool speed	rpm	4,500	4,500	4,500	4,500
	Rotary tool motor (Cont./Max)	kW	5.5/7.5	5.5/7.5	5.5/7.5	5.5/7.5
Tailstock	Quill diameter	mm	110	110	110	110
	Quill stroke	mm	100	100	100	100
	Spindle taper	MT	MT4 (Built-in)	MT4 (Built-in)	MT4 (Built-in)	MT4 (Built-in)
Machine	Size (with Side Chip conveyor) LxWxH	mm	4,009(4,986) × 2,162 × 2,289		5,450(6,506) × 2,162 × 2,289	
	Size (with Rear Chip conveyor) LxWxH	mm	-		-	
	weight	kg	7,000	7,000	10,500	10,500
	Coolant tank capacity	Liter	180	180	261	261
ELECTRIC POWER SUPPLY	kVA/V		50/220	50/220	50/220	50/220
CONTROLLER			FANUC, SIEMENS			

※Design and specifications subject to change without notice.

Standard Accessories

- 12" hollow 3 jaws chuck (A Type)
- 15" hollow 3 jaws chuck (B Type)
- Chuck clamp confirmation
- Chuck clamp foot switch
- Chuck pressure switch
- Coolant system
- Door interlock
- Full splash guard with coolant tank
- Jaw (soft 3set, hard 1set)
- Leveling unit
- Manual/Part list (1set)
- Patrol lamp (3colors)
- Safety precaution name plate
- Spindle orientation
- Tailstock (programmable)
- Tool box
- Tool holders
- Work light (LED lamp)

Optional Accessories

- Air blower
- Air conditioners (electric cabinet)
- Air gun
- Auto door
- Bar Feeder Interface
- Chip bucket
- Chip conveyor
- Coolant gun
- Counter (total, multi, tool, work)
- Dual pressure chucking
- Oil mist collector
- Oil skimmer
- Robot interface
- Special chuck
- Steady rest
- Tool presetter (manual/auto)
- Transformer