

DUGARD

Machine Tools That Create Solutions Since 1939

Dugard ECO Range Vertical Machining Centres



www.dugard.com

Big Cutting Capacity at a Competitive Price



- Fully enclosed with removable side doors
- Heavy duty box ways on all the axes
- Large fully ground table with 4 T-slots
- ISO 40 spindle taper - BT or CAT
- Spindle speed 8,000rpm (standard)
- All axes box ways are hardened and precision ground, all bearing surfaces of guide ways & gibs are precision scraped and plated with Turcite B
- Direct drive axis movement gives fast feed rates
- Large diameter and double pretensioned high precision ball screws on all three axes

Controls Available

Choice of various controls to meet your requirements. Each one features user-friendly operation, powerful functions and maximum dependability



Fanuc 0iMD

- 8.4" TFT LCD colour monitor
- New D series high speed
- PC flash card storage
- Industry standard programming



Heidenhain iTNC 530

- 18" TFT LCD colour monitor
- Super high speed
- Huge programme storage
- Conversational programming



Fagor 8055i Plus

- 11" TFT LCD colour monitor
- High speed function
- Conversational programming



Siemens 828D

- 10.4" TFT LCD colour monitor
- Shopmill conversational programming
- Super high speed
- USB/PC card storage

Various interfaces for programme saving, loading and software updating including:



- CF memory card
- RS-232C
- Ethernet

Structure and Components

Casting

Fine grain Meehanite cast iron offers high tensile strength, as well as long term wear resistance



Model shown
Dugard Eco 1000

Transmission

Direct drive axis movement gives fast feed rate



Spindle

Class P4 preloaded angular contact high precision bearings to guarantee rigidity and speed up to 8000rpm (10,000rpm available on request)



Automatic Tool Changer

Random selection Automatic Tool Changer. The cutting tool is kept clean by built in air blast function in the main spindle performed during tool change

Standard 20 station drum type ATC



Optional 24 station twin arm ATC



The machines' electrical components and wiring systems are all fully CE compliant. Component locations are labeled for easy maintenance

Layout Drawings

Dugard ECO 1000 / 1500 Models

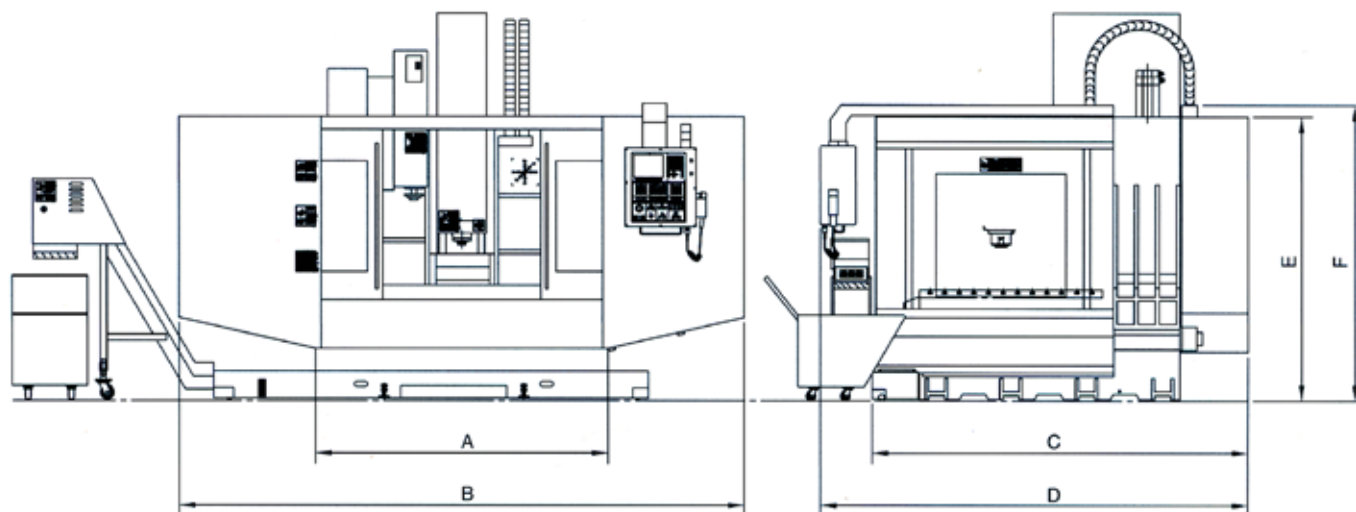

Dimensions (mm)	A	B	C	D	E	F
ECO 1000	-	3370	-	2650	-	2800
ECO 1500	2200	4260	-	3400	-	2820

Dugard ECO 2000 Model

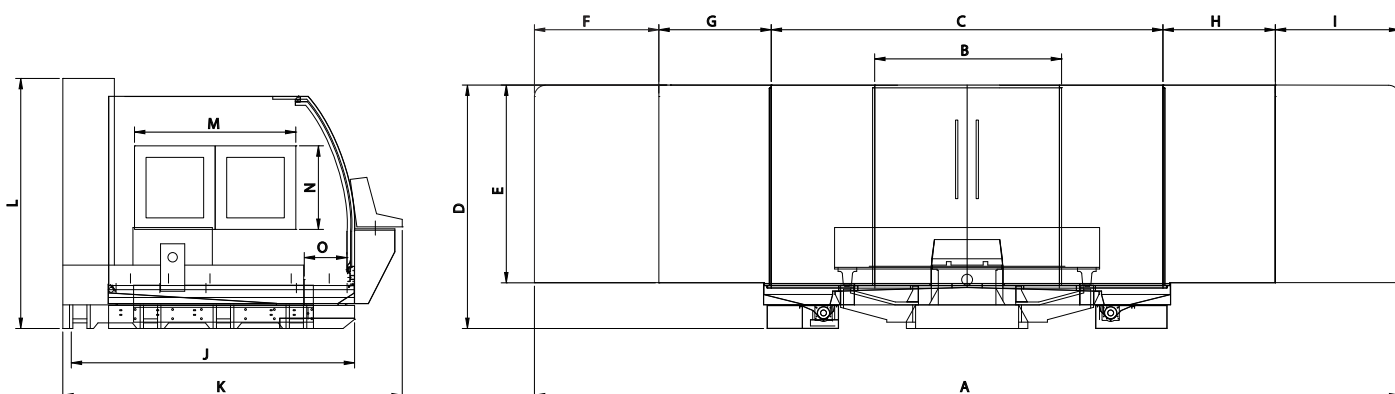

Dimensions (mm)	A	B	C	D	E	F	G
ECO 2000	7634	1800	3534	2113	1717	1080	975
H	I	J	K	L	M	N	O
975	1080	2459	2945.43	2170	1200	800	370

Fanuc 11/15kW - Dugard ECO 1000 Model

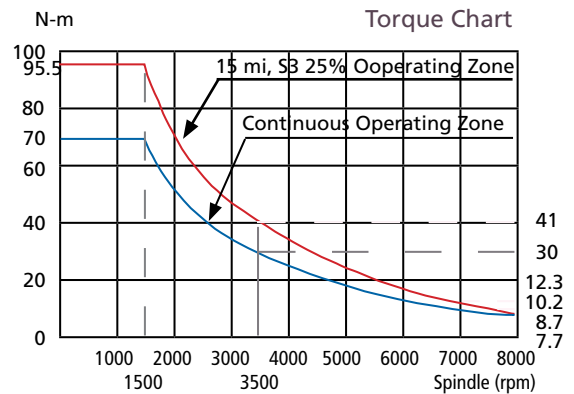
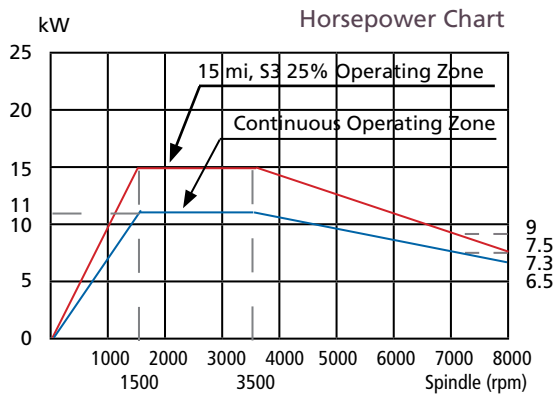

Fagor 11/15kW - Dugard ECO 1000 Model

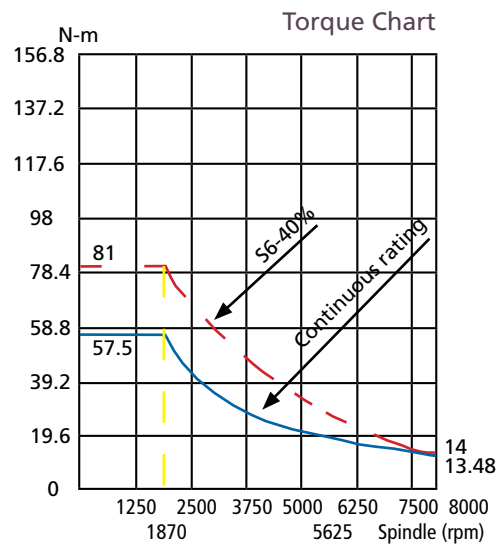
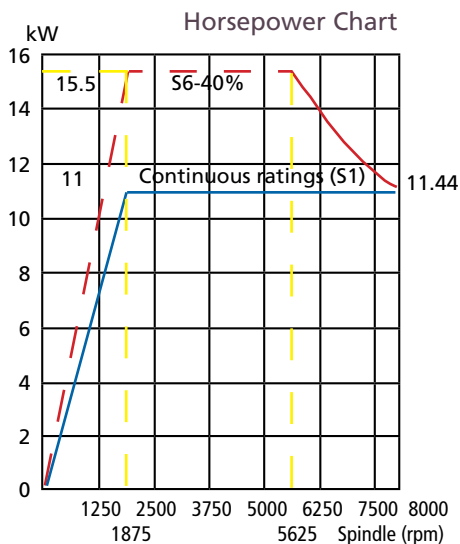

Fanuc 15/18.5kW - Dugard ECO 1500 / 2000 Models

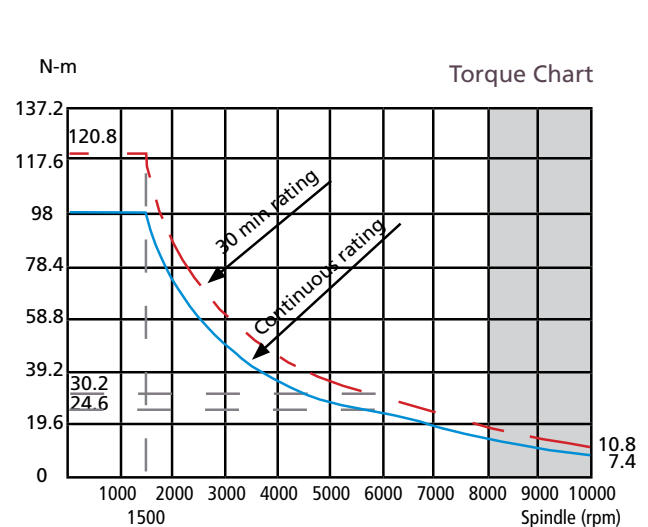
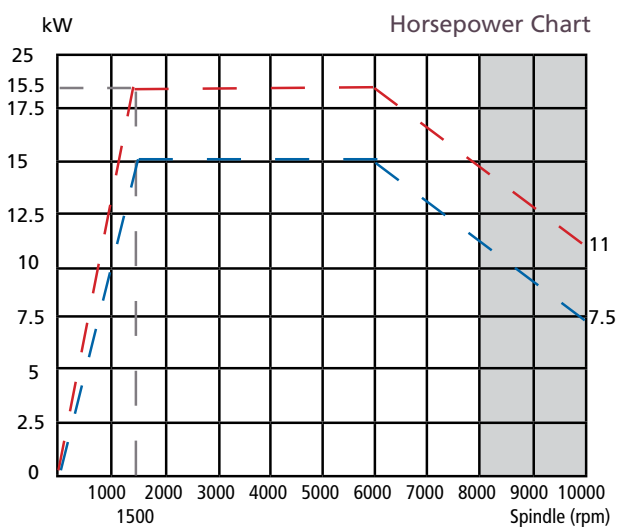

Dugard ECO VMC Accessories

Standard Accessories

- Coolant system
- Automatic lubrication system
- Portable MPG for 3 axes
- Pneumatic power draw bar
- Work light
- CE certified
- Telescopic way cover for Y axis
- Chip flushing

Optional Accessories

- Top enclosure for full guarding roof (for CTS use)
- Coolant through spindle with high pressure pump
- 4th axis

Semi Guarding Option - sold in UAE / CIS only

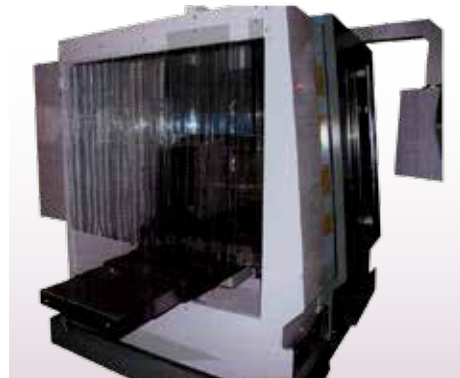

Curtain type semi guarding with extension chip trays for easy loading/unloading of long workpieces

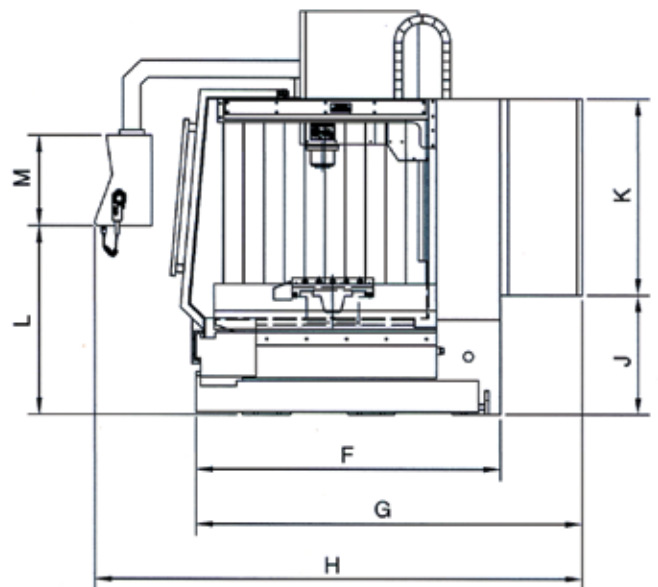
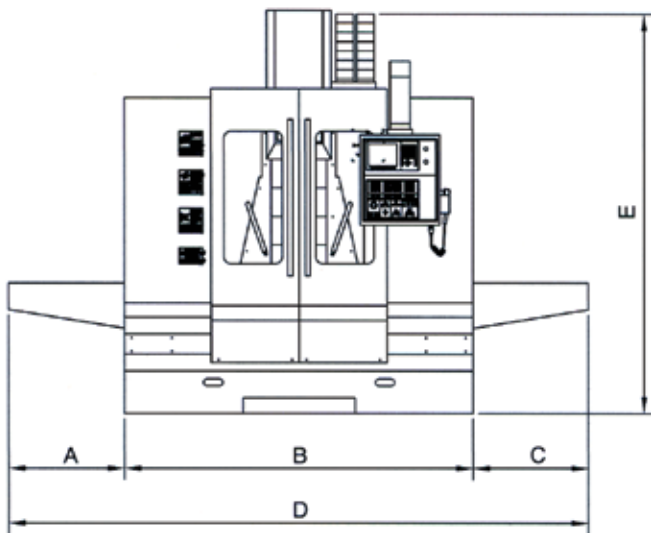

Dimensions (mm)	A	B	C	D	E	F	G	H	J	K	L	M
ECO 1000	723	2180	723	3626	2545	1910	2416	3050	759	1250	1201	574
ECO 1500	1400	2180	1400	4980	2590	2368	2878	3540	692	1495	1217	574

Specification	ECO 1000	ECO 1500	ECO 2000
Table			
Table size	1300 x 600mm	1950 x 610mm	2336 x 762mm
T-slots (no x wid x dis)	5 x 18 x 80mm	5 x 18 x 100mm	5 x 18 x 120mm
Table load	800kg	1500kg	1800kg
Travel			
X axis	1000mm	1510mm	2000mm
Y axis	600mm	740mm	889mm
Z axis	600mm	670mm	710mm
Spindle			
Spindle motor	11/15kW		
Spindle nose to table	110~710mm	120~790mm	100~810mm
Spindle centre to column	675mm		
Spindle taper	BT40 (CAT/Din opt)		
Spindle speed	8000rpm (10,000rpm opt)		
Spindle diameter	150mm		
Feedrates			
Rapids on (X / Y / Z) axes	24m/min		20m/min
Cutting feedrate	10 / 10 / 10 m/min		
Accuracy			
Positioning	±0.005/300		
Repeatability	0.005		
Tool Changer			
Tool capacity	20 carousel (24 twin arm opt)		
Tool shank	BT40 (CAT/Din opt)		
Pull stud	MAS P40T		
Maximum tool diameter with adjacent tool	90 / 75mm		
Maximum tool weight	8kg		
Motor			
Drive motor X, Y, Z digital	1.8 / 1.8 / 2.5kW		
Coolant pump	850W		
General			
Power required	35kVA		
Air required	400L/min		
Floor space (L x W x H)	5230 x 3295mm	4250 x 4200mm	6900 x 4340mm
Machine weight	5000kg	6000kg	7500kg

* Specifications are subject to change without notice

DUGARD Machine
Tools

www.dugard.com | sales@dugard.com | +44 (0)1273 732286