

# SMEC

## SL 5500 series

HORIZONTAL TURNING CENTER



SMEC Co., Ltd.  
157-10, Goldenroot-ro, Juchon-myeon, Gimhae-si, Gyeongsangnam-do, Korea  
Tel +82 55 340 4800 Fax +82 55 340 4740  
<http://www.esmec.com>



✦ Design and specifications subject to change without notice.

© SMEC 2018.03-NO.1



- 1988 - Started as Samsung Heavy Industries Machine Tools Business
- 1989 - Horizontal and vertical machining center technology partnership with OKK Japan
- 1991 - Turning center and vertical machining center technology partnership with Mori Seiki
- 1996 - 5-sided processing center technology partnership with Toshiba
- 1999 - Spun out from Samsung Aerospace Industries and established SMEC Co., Ltd

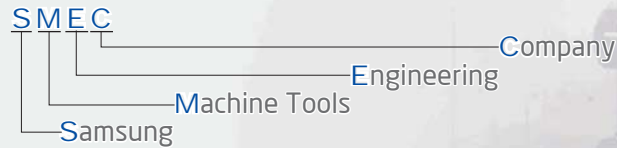

## SL 5500/5500M

- A Type : Chuck Size 21"**
- B Type : Chuck Size 24"**
- C Type : Chuck Size 32"**

Strongest in class with superb structural design  
Simultaneous heavy duty and precision turning

- 45 degree torque tube type bed to support heavy duty turning
- Significantly reduced non-cutting time and efficient turning
- Low-center of gravity reducing vibration, thermal deformation and improving rigidity

## High Accuracy, High Rigidity Spindle

### Pin Tube Rib Design for Minimal Axis Heat Transfer

Radiator fan-like pin tube rib design dissipates heat generated by axis movements, maintaining minimal thermal expansion.

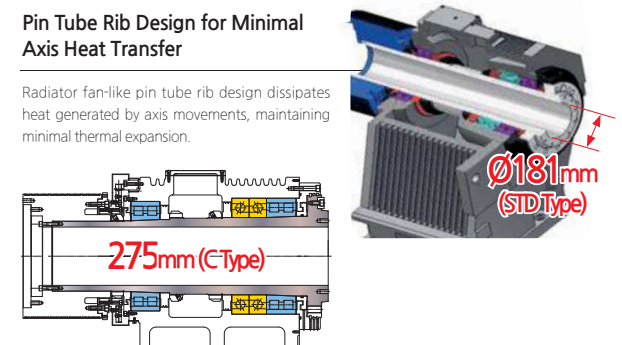

### Output Converting Transmission



Equipped as standard feature, high Output Converting Transmission provides heavy-duty machining.

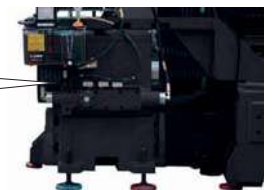

### Spindle Power & Torque Diagram

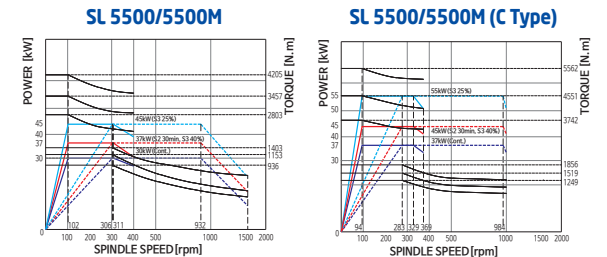

SL 5500 series  
HORIZONTAL TURNING CENTER

An innovative high precision, heavy duty CNC Lathe,  
integrated with all of SMEC's advanced technology  
- SL 5500 series

Spindle speed  
**1,500 rpm** (STD Type)  
**1,000 rpm** (Big Bore Type)



Max. machining length[MC(BMT 75/85)]  
**1,097 [(1,079/1,045)] mm** (SL5500/M)  
**2,197 [(2,179/2,145)] mm** (SL5500L/LM)  
※Machining Length : 2000, 3000 Possible

Spindle motor(cont./30min)  
**30/45 kW** (STD Type)  
**37/55 kW** (Big Bore Type)

Rapid traverse(X/Z)  
**20/20 m/min**

Max. machining dia.[BMT 85]  
**Ø690 [Ø650] mm**

Highly Reliable and Rigid Structural Design

- One piece Meehanite casting with heavily ribbed torque tube design
- Rigid bed supports for powerful cutting
- Excellent vibration dampening and thermal displacement design

SL 5500 (High Speed Servo Index Hydraulic Turret)



Indexing Time  
**0.25 sec(60 Hz)**

Number of tool positions  
**12 stations**

High Speed, Heavy Duty Servo Turret

Driven by a high torque servo motor, the 12-station heavy -duty turret can accept tools on both left and right side of each station. Turret indexing (repeatability ± 0.01) is non-stop, bi-directional with a fast 0.25 second next station index time. Large diameter (Ø320) precision Curvic coupling with 159,300N clamping force enables precision as well as heavy-duty cutting.

SL 5500M (BMT High Speed Turret)



Turret Torque Diagram(BMT75)

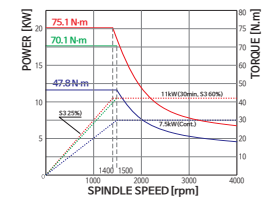

Indexing Time  
**0.25 sec(60 Hz)**

Number of tool positions  
**12 stations**

Milling Spindle Speed  
**4,000 rpm(3,000 with BMT85/opt.)**

Tool Holder  
**BMT 75(85 Opt.)**

BMT Milling Turret (M Type)

SL 5500M is equipped with standard 12-station BMT turret capable of accepting rotary tools at any station, providing flexible machining thru various machining operations in just one set-up. Each BMT holder is securely tightened by 4~6 screws, allowing the turret to perform heavy-duty cutting, milling and drilling operations. Turret indexing is non-stop, bi-directional with a fast 0.25 second next station index time.

SL 5500 series  
HORIZONTAL TURNING CENTER



**Centralized Operation Panel**

The centralized operation panel with its 10.4 inch color TFT LCD monitor is able to swivel 90 degrees, providing operators with easy access to the control panel while working on the machine.



**Rigid 45 degree Slant Bed**

45 degree slant torque tube design bed and wide guide slide way ensure long term rigidity and machining accuracy.

Also, the Slant Type structure allows for easier access to the workpiece and superb chip discharge.

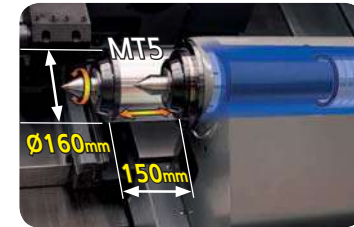
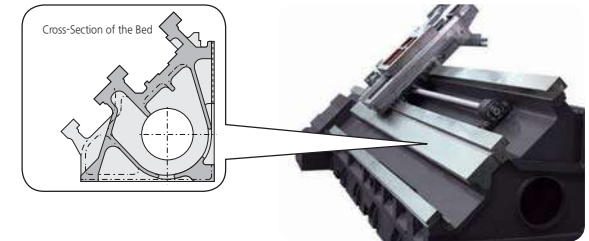

**Programmable Tailstock(Carriage direct-coupled) [Std.]**

The programmable tailstock body mounted is on wide guide ways to ensure rigid work piece support.

**Fast Indexing and Heavy-Duty Turret Design**

All axes ballscrews are pre tensioned, heat treated and fixed by double anchors on both ends, providing ultimate rigidity and minimal thermal growth. Both ends are supported by P4 class high precision angular bearing and run by big Dia. high precision ballscrews.

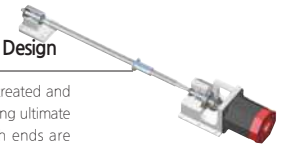

**Hexahedral Slide Way Frame (X-axis)**

Wide integral way is machined from the casting, induction hardened and precision ground to ensure long-term rigidity, machining accuracy and heavy-duty machining.

**High Precision**

Surface Roughness

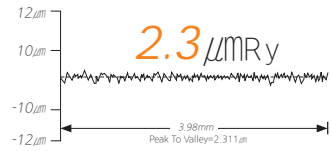

Model : SL 5500

Roundness

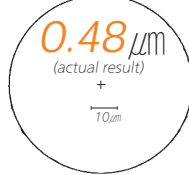

Cutting condition	
Tool	Diamond tool <nose radius 0.5mm>
Material	AL150<Aluminum>
Cutting speed	230 m/min
Feedrate	0.05 mm/rev
Depth of cut	0.1 mm
Outer diameter	200 mm
Filter	1-50

**Processing Speed**

Turning Performance (material:SM45C) SL 5500

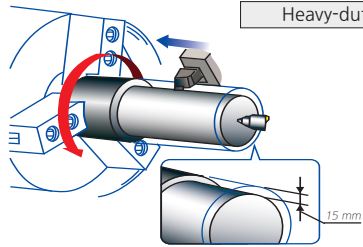

Heavy-duty cutting (O.D) <32mm×32mm qualified tool>

Spindle speed  
**367 rpm**  
Cutting speed  
**150 m/min**  
Depth of cut  
**15 mm <Spindle Load 65%>**  
Feedrate  
**0.4 mm/rev**

**Standard Accessories**

**Optional Accessories**

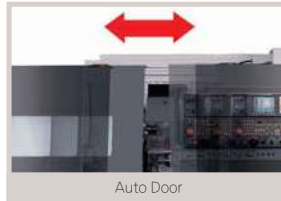

**Machine Dimensions**

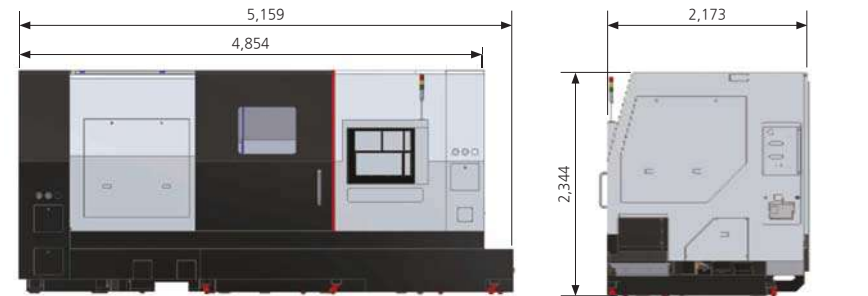

**Tooling System**

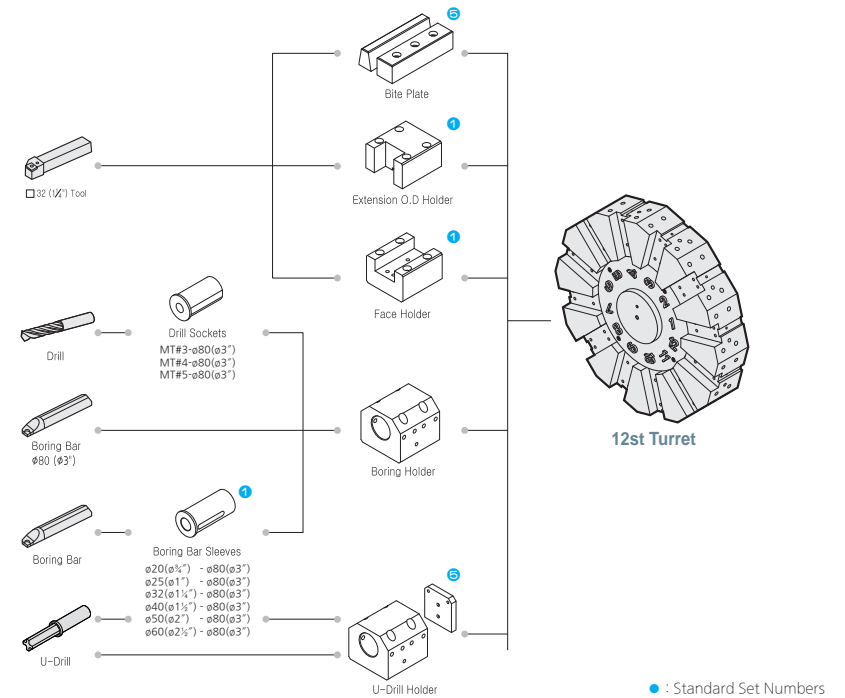

Tooling System

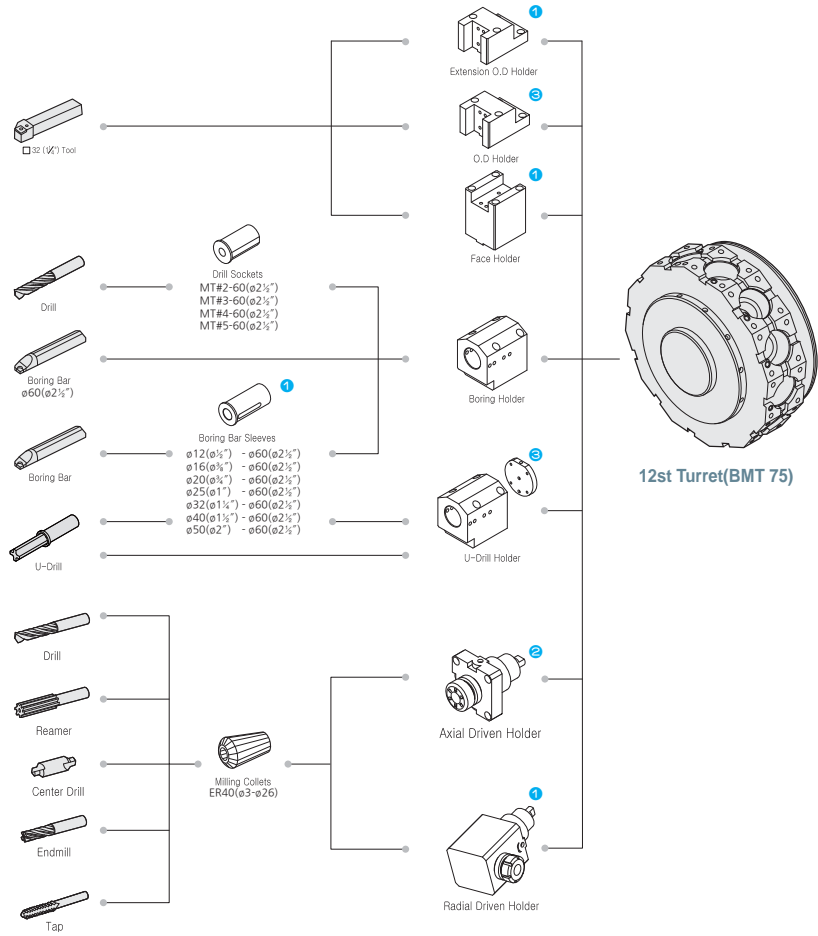

● : Standard Set Numbers

Tooling System

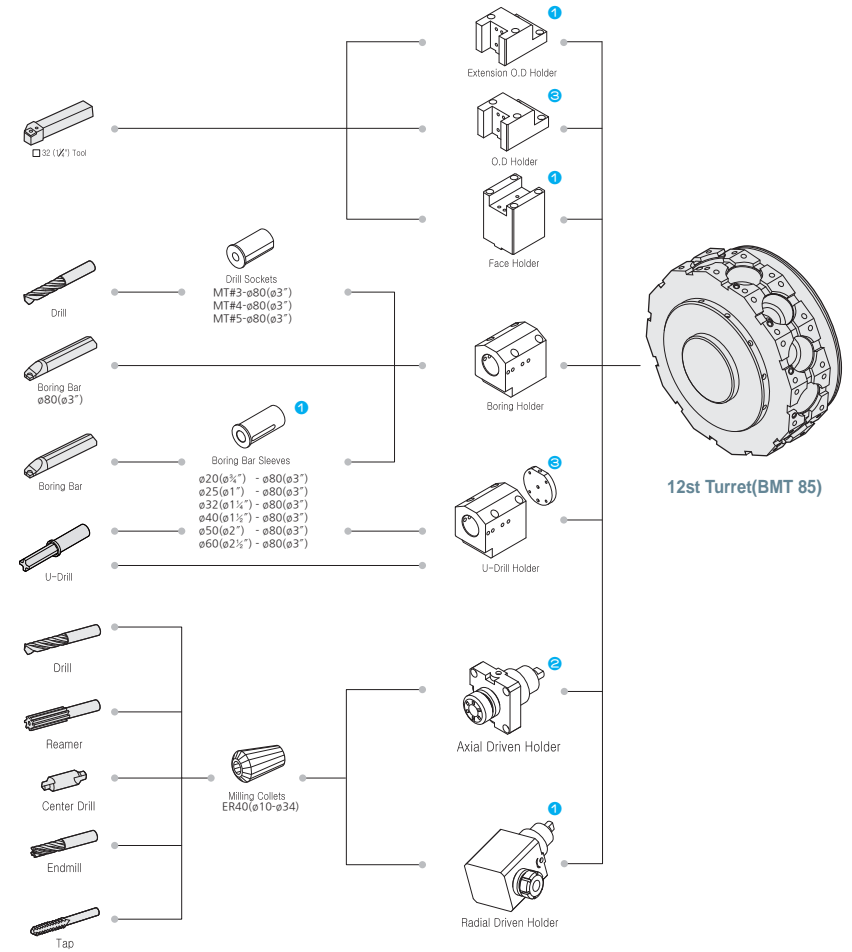

● : Standard Set Numbers

Work Range

Unit : mm

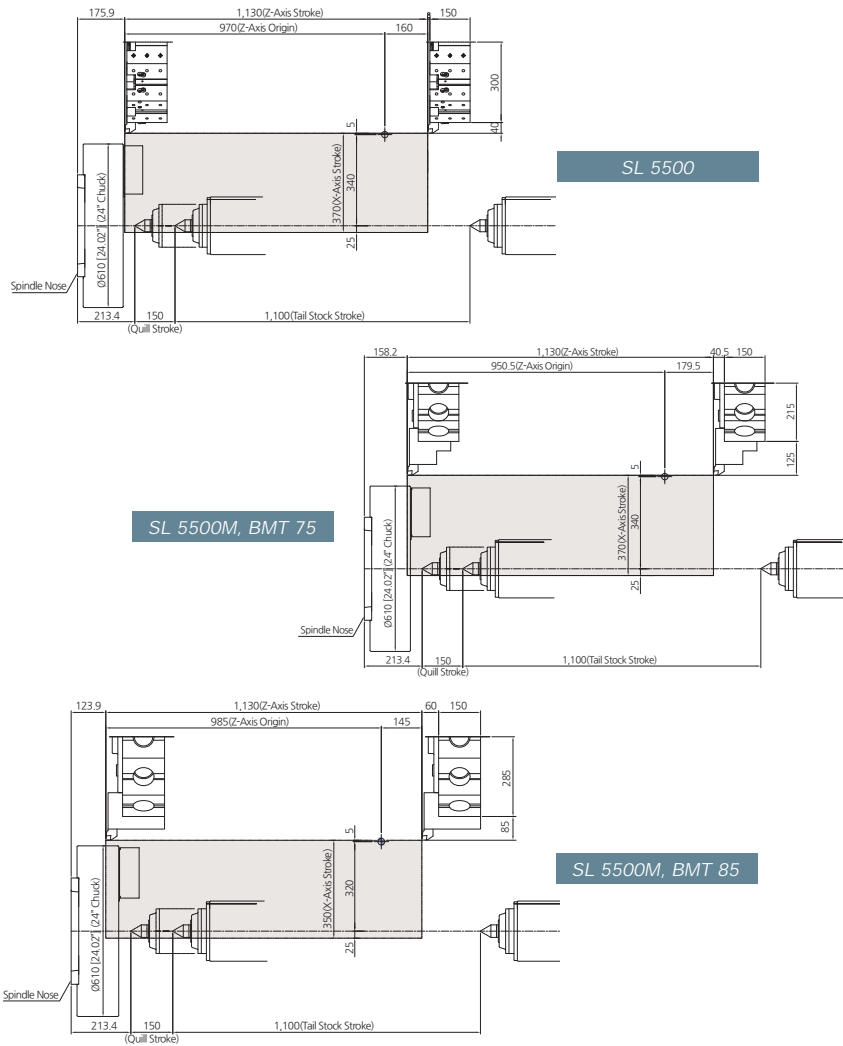

Turret Interference

Unit : mm

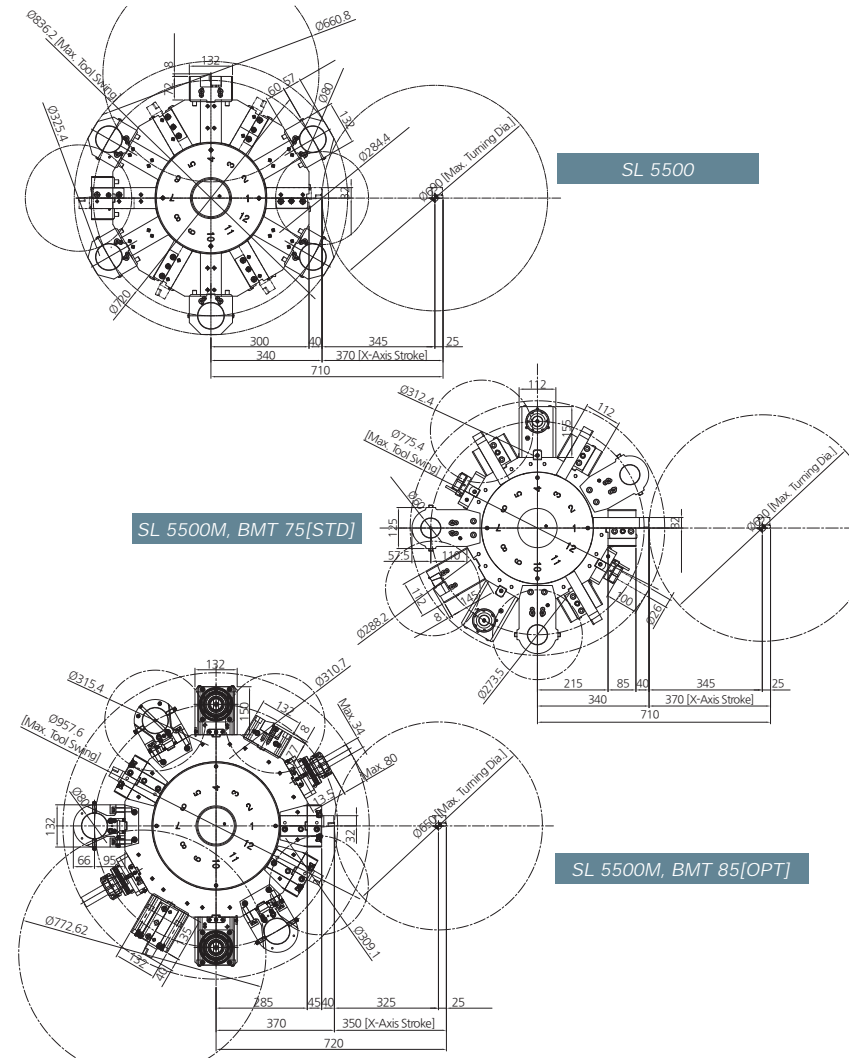

**Major Specifications**

DESCRIPTION			SL 5500	SL 5500M
Chuck	Chuck size	inch	A Type:21", B Type:24", C Type:32"	A Type:21", B Type:24", C Type:32"
Capacity	Swing over the bed	mm	900	900
	Swing over the cross slide	mm	800	800
	Max. turning diameter	mm	690	690 [650]
	Max. Milling diameter	mm	-	793(704)
	Max. turning length (*)	mm	1,097(*)	1,079(*)
Travels	Draw tube ID	mm	165.5(231)	165.5(231)
	X axis travel	mm	370	370 [350]
Main Spindle	Z axis travel	mm	1,130	1,130
	Max. spindle speed	rpm	1,500[1,200](1,000)	1,500[1,200](1,000)
	Spindle nose	ASA	A2-15(A2-20)	A2-15(A2-20)
	Spindle bore diameter	mm	181	181
	Min. spindle indexing angle(C-Axis)	deg	-	0.001
Turret	Number of tool stations [option]	ea	12	12/BMT75 [BMT85]
	Shank size for square tool	mm	32	32
	Shank diameter for boring bar	mm	80	60 [80]
	Indexing time	sec	0.25	0.25
	Rotary tool spindle speed	rpm	-	4,000 [3,000]
Feed Rate	Rapid traverse (X/Z)	m/min	20/20	20/20
Motor	Spindle drive motor(cont./30min)	kW	30/45(37/55)	30/45(37/55)
	Rotary tool spindle motor(cont./30min)	kW	-	11/7.5
Tailstock	Tailstock quill stroke	mm	150	150
	Quill diameter	mm	160	160
	Quill bore taper	M	MT5(BUILT-IN)	MT5(BUILT-IN)
ELECTRIC POWER SUPPLY	kVA/V	62/220(71/220)	62/220(71/220)	
FLOOR SPACE(with chip conveyor)(LxWxH)	mm	5,159(6,040)×2,173×2,344		
MACHINE WEIGHT	kg	15,000(15,500)	15,500(16,000)	
CONTROLLER		Fanuc Series		

\*Figures in inches are converted from metric measurements.  
 (+):2000, 3000 Possible

[ ] : Option  
 ( ) : C Type

**Standard Accessories**

- Coolant System (4.5 bar-60Hz)
- Work light (Led lamp)
- Splash guard with side coolant tank
- Tool box
- 21" Hyd. Hollow chuck(SL 5500/M)
- Soft Jaw
- Leveling unit

- Main spindle orientation
- Chuck clamp foot switch
- Chuck clamp confirmation
- Chuck pressure switch
- Manual/Part list
- Door interlock
- Patrol Lamp

**Optional Accessories**

- Chuck(SL 5500C/CM)
- Side chip conveyor
- Chip bucket
- Special chuck
- Dual pressure chucking
- Air gun
- Air blower
- Oil skimmer
- Chuck coolant
- Coolant gun
- Steady Rest(ASR 4.0/5.1)
- Hard Jaw

**NC Specifications / FANUC Series**

Item	Specification	
Controlled axis	Controlled Axes	2 axis(X,Z)
	Max. Simultaneously Controlled Axes	Positioning(G00) / Linear Interpolation(G01) Circular Interpolation(G02, G03)
	Least Input Increment	0.001mm
Spindle Function	Spindle Speed Control	S5 (5 digit)
	Spindle Speed Override	0-120%
	Spindle Orientation	M19
Feed Function	Feedrate Override (10% increase)	0-150%
	Dwell	G04
	Reference Position Return	G27, G28
	Manual Pulse Generator	0.001/0.01/0.1mm
	Dry Run	F0(Fine Feed), 25/50/100%
Tool Functions	Rapid Traverse Override	F0(Fine Feed), 25/50/100%
	Tool Number Command	T2(2 Digit), T4(Digit)
	Tool nose radius compensation	G40 - G42
	Tool offset pair	128EA
Programming Function	Tool geometry/wear offset	GEOMETRY & WEAR DATA
	Canned Cycle	G70-G72, G74-G76
	Decimal Point Input	Able to input up to decimal point
	Sub Program	4Phase
	Work Coordinate System	G52-G59
	Max Program Dimension	±99999.999mm
Tape Functions	M Function	M3(3 Digit)
	Input Code	ISO/EIA Auto Recognition
	I/O Interface	RS232C
	rogram Storage Space	1280M(512kb)
	Number of stored programs	400EA
Other Functions	Display Unit / MDI	10.4" color LCD / Soft input type MDI
	Synchronized Tapping	Rigid Tapping Function
	Background Tapping	Program saving/editing during automatic operation
	Backlash Compensation	Pitch Error Offset Compensation for Each Axis
	Search Function	Sequence / program number search
	Safety Function	Emergency stop / overtravel
	Program Test Function	Machine Lock / Single Block
	Control Function	Memory / MDI / Manual
	Mirror Image	
	Run hour and parts count display	
Custom Macro	#100 ~ #199, #500 ~ #999	