

NC Unit Specifications / FANUC Series

	Item	Specification	Fanuc Series	
Controlled axis	Max. feed axes		4 AXIS	
	Feed axes		X/Z/(Cs)	
	Max. simultaneously controlled axis		4	
	Least command increment	0.001mm / 0.0001"	○	
Operation functions	Pulse handle feed	X1, X10, X100	○	
	Feedrate per minute	G98	○	
	Feedrate per revolution	G99	○	
Interpolation functions	Linear interpolation	G01	○	
	Circular interpolation	G02, G03	○	
	Dwell	G04	○	
	Polar coordinate interpolation	G12.1, G13.1	○	
	Cylindrical interpolation	G70.1	○	
	Variable lead thread cutting	G34	○	
	Continuous threading		○	
	Reference position return	G28	○	
	Reference position return check	G27	○	
	Rapid traverse rate override	F0, 25%, 50%, 100%	○	
Feed function	Feedrate override		0~150%	
	Spindle orientation	M19	○	
Spindle function	Rigid tapping		○	
	Tool number command	T4-Digt / T2-Digt	T4-Digt	
Tool functions	Tool nose radius compensation	G40 ~ G42	○	
	Tool offset pairs	128	○	
	Tool geometry/wear offset	GEOMETRY & WEAR DATA	○	
	Tool life management		○	
	Tool path graphic display		○	
	Automatic tool offset	G36, G37	○	
	Direct input of tool offset value measured B		○	
	Absolute/incremental programming		○	
	Multiple repetitive cycle	G70 ~ G76	○	
	Canned cycles	G90, G92, G94	○	
Program input	Inch/metric conversion	G20 / G21	○	
	Program restart		○	
	Retraction for rigid tapping		○	
	Max. programmable dimension	±99999.999mm/±9999.9999"	○	
	M function	M3 digit	○	
	Custom macro	#100~#199, #500~#999	○	
	Canned cycle for drilling		○	
	Direct drawing dimension programming		○	
	Programmable data input	G10	○	
	Optional block skip		○	
	Workpiece coordinate system	G52 ~ G59	○	
	Number of registerable programs		400EA	
	Setting and display	Alarm & Operator history display	ALARM & OPERATION DISPLAY	○
		Run hour and parts count display	RUNNING TIME & PART NO. DISPLAY	○
		Display spindle & servo overload	SPINDLE & SERVO LOAD DISPLAY	○
Self-diagnosis function			○	
Extended part program editing		COPY, MOVE, CHANGE OF NC PROGRAM	○	
Data input/output	Display screen		10.4" color	
	Memory card input/output		○	
Editing operation	USB memory input/output		○	
	Part program storage size	512Kbyte(1280m)	○	
Manual guide i	Manual Guide i		○	



SMEC Co., Ltd.
 157-10, Goldenroot-ro, Juchon-myeon, Gimhae-si, Gyeongsangnam-do, Korea
 Tel +82 55 340 4800 Fax +82 55 340 4740
<http://www.esmec.com>



◆ Design and specifications subject to change without notice

© SMEC 2018.03-NO.1

SMEC

SL 4500Y series

CNC TURNING CENTER



- 1988 - Started as Samsung Heavy Industries Machine Tools Business
- 1989 - Horizontal and vertical machining center technology partnership with OKK Japan
- 1991 - Turning center and vertical machining center technology partnership with Mori Seiki
- 1996 - 5-sided processing center technology partnership with Toshiba
- 1999 - Spun out from Samsung Aerospace Industries and established SMEC Co., Ltd

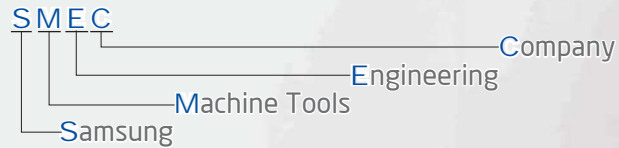

SMEC'S Advanced Engineering and Machine Design

SL 4500LY/4500XLY

- A Type : Chuck Size 18" (15")**
- B Type : Chuck Size 21"**
- C Type : Chuck Size 24"**

- Cast iron structure for superior dampening characteristics and thermal displacement
- Rigid 45 degree slant bed design for heavy-duty machining
- Torque tube design to minimize bending and twisting
- Integrated box ways for long-term rigidity and heavy-duty machining



High Accuracy, High Rigidity Spindle

Pin Tube Rib Design for Minimal Axis Heat Transfer

Radiator fan-like pin tube rib design dissipates heat generated by axis movements, maintaining minimal thermal expansion.

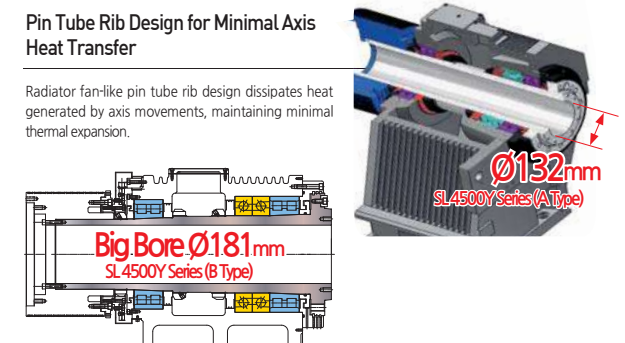

Output Converting Transmission



Equipped as standard feature, high Output Converting Transmission provides heavy-duty machining.

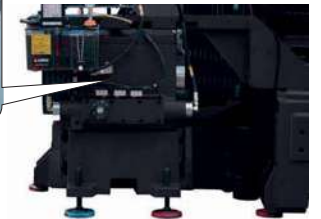

Swivel Operation Panel

Swivel operation panel of 10.4 inch color TFT LCD monitor can turn to 90 degree, providing operators with easy access to the control panel while working on the machine.

SL 4500LY/45XLY

CNC TURNING CENTER

SL 4500LY is a heavy duty, ultra precision Turning Center, combined with **SMEC's** advanced technological features.

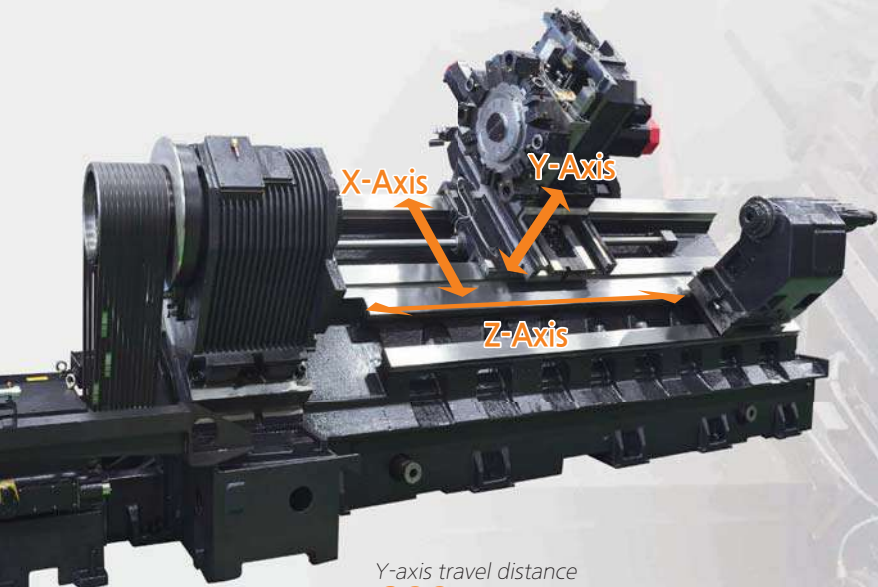

Y-axis travel distance
200(±100) mm

Y-axis rapid traverse rate
15 m/min

Turret Torque Diagram

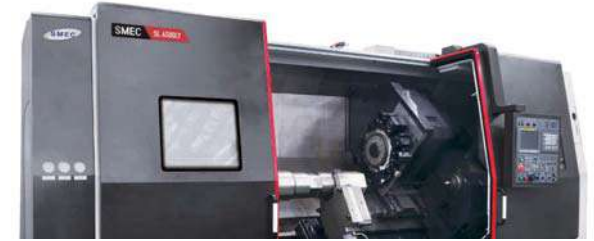
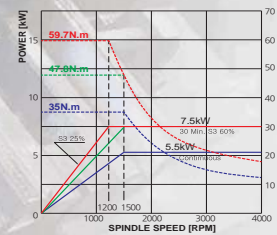

Spindle Speed
2,000 rpm
Spindle Motor(30min/cont.)
37/30 kW
Rapid Travel(X/Y/Z)
20/15/18 m/min

Indexing Time
0.25 sec (60 Hz) Number of tool positions
12 stations

Virtual Y-axis function

In the Y-axis plane, tools can move in a plus or minus direction perpendicular to the Z-axis and spindle center line. Viewed from the operator's perspective, this Y-axis motion is toward or away from the door of the machine while X-axis moves from floor to ceiling.

Y-axis enables various shape of cutting. Y-axis is realized virtually by the linear interpolation and synchronous movement of X1 and X2-axis that make it possible to lower machine height for stability.

Spindle Power & Torque Diagram

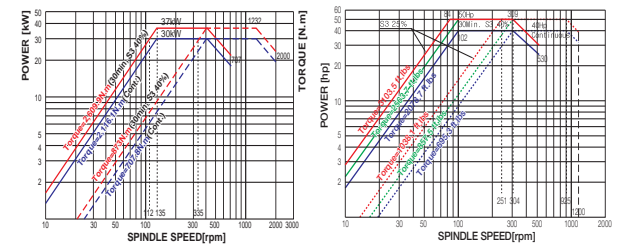

SL 4500LY/45XLY

CNC TURNING CENTER

High-productivity Compact Turning Center with Y-axis Based on SL 4500 Series

SL 4500LY/45XLY

SL 4500 series addition of stable and rigid Y-axis based on SL 4500 model makes possible to complete machining in 1 set-up. The longest Y-axis off-center machining is available, and through reducing cycle time and non cutting time provides your productivity improvement.

Added with Y-axis

The addition of Y-axis to the SL 4500 Series provides travel stability, higher precision and higher rigidity leading to improved productivity.

High productivity

All the axis are applied with fast, accurate and high rigidity, box guide minimize idle time and maximize productivity.



Rigid 45 degree Slant Bed

45 degree slant torque tube design bed and wide guide slide way ensure long term rigidity and machining accuracy.

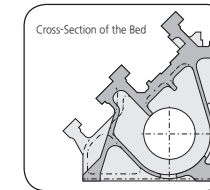

Featuring superior workability and chip-discharging capability, the bed is designed in a single tube structure boasting strong durability even in heavy-duty cutting.

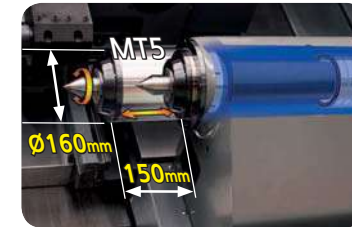

Programmable ailstock (Carriage direct-coupled)

The programmable tailstock body mounted on wide guide ways ensure rigid work piece support.

Pre-tensioned and Double Anchored Ballscrews

All axes ballscrews are pre-tensioned, heat treated, and fixed by double anchors on both ends, providing ultimate rigidity and minimal thermal growth.

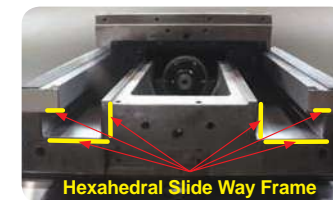

Hexahedral Slide Way Frame

Wide integral way is machined from the casting, induction hardened and precision ground to ensure long-term rigidity, machining accuracy and heavy-duty machining.

High Precision

Surface Roughness <O.D. cutting>

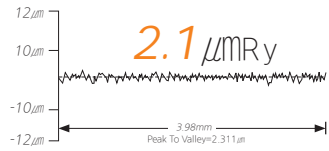

Model : SL 4500LY

Roundness

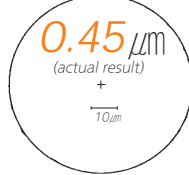

Cutting condition	
Tool	Diamond tool <nose radius 0.5mm>
Material	AL150<Aluminum>
Cutting speed	230 m/min
Feedrate	0.05 mm/rev
Depth of cut	0.1 mm
Outer diameter	200 mm
Filter	1-50

Processing Speed

Turning Performance (material:SM45C) SL 4500LY

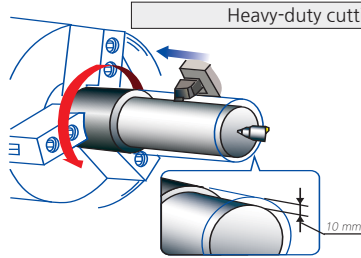

Heavy-duty cutting (O.D) <32mm×32mm qualified tool>

Spindle speed
367 rpm
Cutting speed
150 m/min
Depth of cut
10 mm <Spindle Load 65%>
Feedrate
0.4 mm/rev

Standard Accessories

Optional Accessories

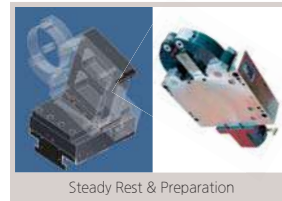
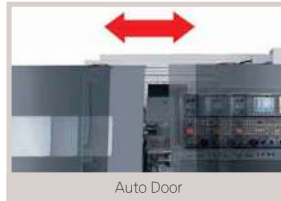
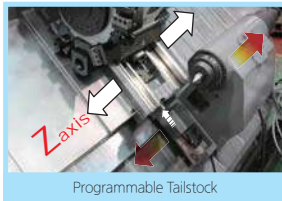

Tooling System

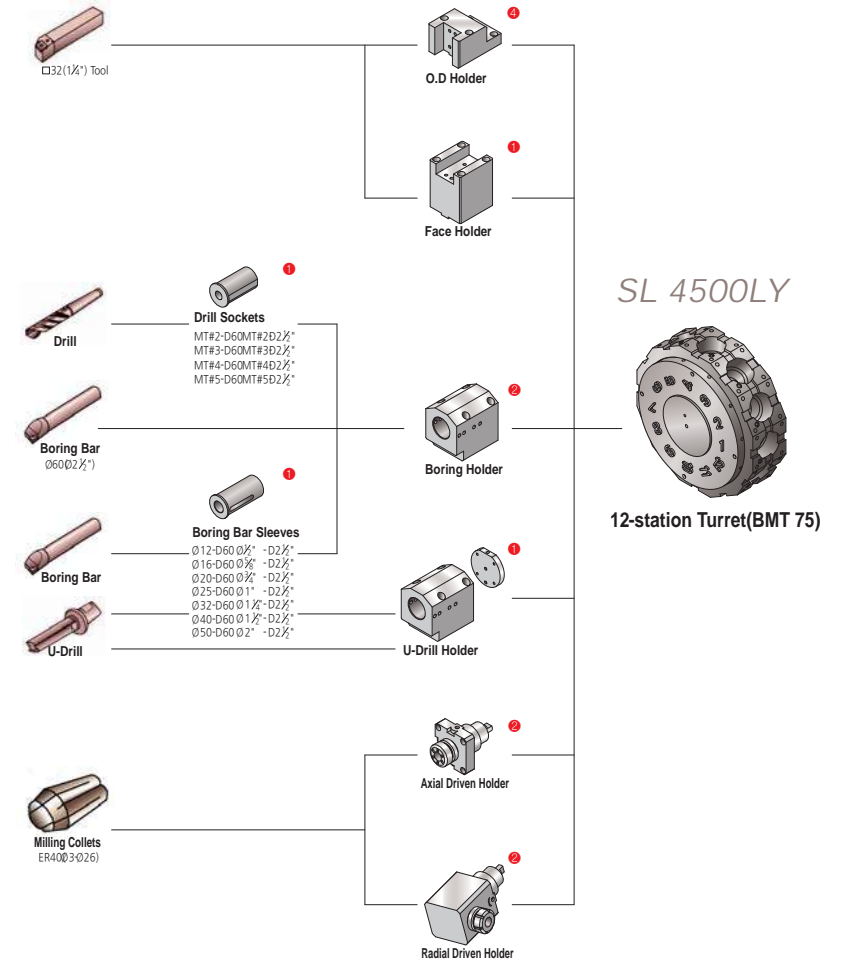

● : Standard Set Numbers

SL 4500LY/45XLY

CNC TURNING CENTER

Machine Dimensions

Unit : mm

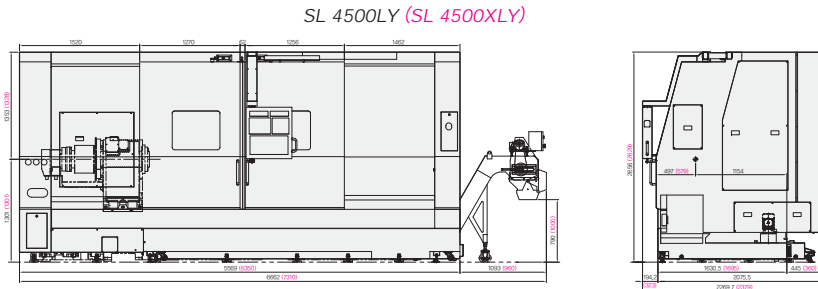

Turret Head Interference

Unit : mm

HYD TURRET (STD 12 station)

MILL TURRET (BMT 75)

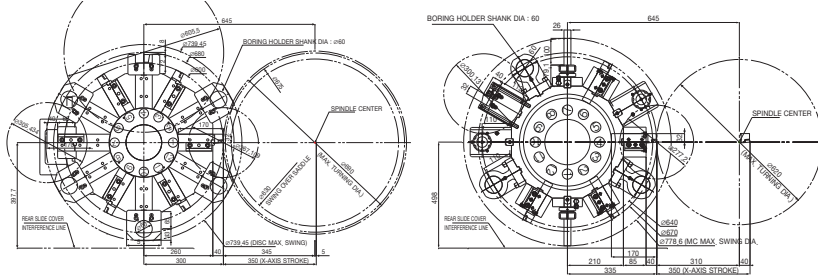

Work Range

Unit : mm

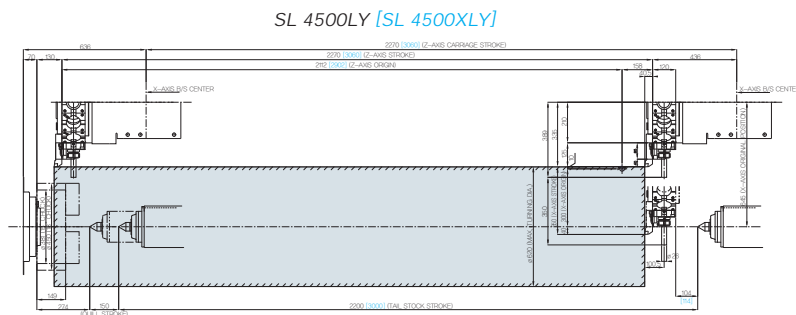

Major Specifications

DESCRIPTION		SL 4500LY	SL 4500XLY
CHUCK	Chuck size	inch A Type:18[15], B Type:21", C Type:24"	A Type:18[15], B Type:21", C Type:24"
	Swing over bed	mm 0975	0975
CAPACITY	Swing over saddle	mm 0830	0830
	Max. machining diameter	mm 0620	0620
	Max. machining length (+)	mm 2,140(+)	2,930(+)
	Bar working diameter	mm 0117	0117
TRAVELS	X-axis travel	mm 350	350
	Y-axis travel	mm 200(±100)	200(±100)
	Z-axis travel	mm 2,270	3,060
SPINDLE	Spindle speed	rpm 2,000 [1,800]	2,000 [1,800]
	Spindle nose	ASA A2-11	A2-11
	Spindle through hole diameter	mm 0132	0132
TURRET	Min. spindle indexing angle	deg 0.001	0.001
	Number of tool stations [option]	ea 12(BMT75)	12(BMT75)
	Shank size for square tool	mm □32	□32
	Shank diameter for boring bar	mm 060	060
	Indexing time	sec 0.25	0.25
	Rotary tool spindle speed	rpm 4,000	4,000
FEED RATE	Rapid traverse (X/Y/Z)	m/min 20 / 15 / 18	20 / 15 / 10
TAILSTOCK	Spindle drive motor(cont./Max.)	kW 30 / 37	30 / 37
	Rotary tool spindle motor(cont./Max.)	kW 5.5 / 7.5	5.5 / 7.5
	Tailstock travel	mm 2,200	2,200
	Quill diameter	mm 0160	0160
	Quill bore taper	MT MT-5(BUILT-IN)	MT-5(BUILT-IN)
REQUIRED FLOOR SPACE(L×W×H)	mm	5,570×2,260×2,659	6,350×2,374×2,629
MACHINE WEIGHT	kg	17,000	22,000
CONTROLLER		Fanuc Series	Fanuc Series

※ Design and specifications subject to change without notice.

※Opt. : []

(+) : 1250, 5000 Possible

Standard

- Coolant system (4.5bar-60Hz)
- built-in work light
- Splash guard
- Hand tools
- Soft jaw
- Tool holder
- Leveling block
- Programmable tailstock
- Spindle orientation
- Door interlock
- 15" Hydraulic chuck(Hollow)
- Chuck Clamp Confirmation
- * Door Interlock, Chuck Clamp Confirmation are CE, KCS standard.

Optional Accessories

- Chip conveyor with bucket
- Auto measuring unit(Q-setter)
- 18" Hydraulic chuck(Hollow)
- Steady rest : SLU-4
- Dual steady rest : SLU-4
- High pressure coolant (6,10,15 bar-60Hz)
- Autodoor & Edge Sensor
- Oil skimmer
- Coolant gun
- Air blower
- Transformer
- Patrol Lamp
- Hard jaw