

NC Specifications / FANUC Series

| | Item | Specification | Oi-TF |
|-----------------------------|--|----------------------------------|-------------|
| Controlled axis | Max. feed axes | | 4 AXIS |
| | Feed axes | | X/Z/(Cs) |
| | Max. simultaneously controlled axis | | 4 |
| | Least command increment | 0.001mm / 0.0001" | ○ |
| Operation functions | Pulse handle feed | X1, X10, X100 | ○ |
| | Feedrate per minute | G98 | ○ |
| | Feedrate per revolution | G99 | ○ |
| Interpolation functions | Linear interpolation | G01 | ○ |
| | Circular interpolation | G02, G03 | ○ |
| | Dwell | G04 | ○ |
| | Polar coordinate interpolation | G12.1, G13.1 | ○ |
| | Cylindrical interpolation | G70.1 | ○ |
| | Variable lead thread cutting | G34 | ○ |
| | Continuous threading | | ○ |
| | Reference position return | G28 | ○ |
| Feed function | Reference position return check | G27 | ○ |
| | Rapid traverse rate override | F0, 25%, 50%, 100% | ○ |
| Spindle function | Feedrate override | | 0~150% |
| | Spindle orientation | | ○ |
| Tool functions | Rigid tapping | | ○ |
| | Tool number command | T4-Digt / T2-Digt | T4-Digt |
| | Tool nose radius compensation | G40 ~ G42 | ○ |
| | Tool offset pairs | | ○ |
| | Tool geometry/wear offset | GEOMETRY & WEAR DATA | ○ |
| | Tool life management | | ○ |
| | Tool path graphic display | | ○ |
| | Automatic tool offset | G36, G37 | ○ |
| Program input | Direct input of tool offset value measured B | | ○ |
| | Absolute/incremental programming | | ○ |
| | Multiple repetitive cycle | G70 ~ G76 | ○ |
| | Canned cycles | G90, G92, G94 | ○ |
| | Inch/metric conversion | G20 / G21 | ○ |
| | Program restart | | ○ |
| | Retraction for rigid tapping | | ○ |
| | Max. programmable dimension | ±99999.999mm/±9999.9999" | ○ |
| | M function | M3 digit | ○ |
| | Custom macro | | ○ |
| | Canned cycle for drilling | | ○ |
| | Direct drawing dimension programming | | ○ |
| | Programmable data input | G10 | ○ |
| | Optional block skip | | ○ |
| Workpiece coordinate system | G52 ~ G59 | ○ | |
| Setting and display | Number of registerable programs | | 400EA |
| | Alarm & Operator history display | ALARM & OPERATION DISPLAY | ○ |
| | Run hour and parts count display | RUNNING TIME & PART NO. DISPLAY | ○ |
| | Display spindle & servo overload | SPINDLE & SERVO LOAD DISPLAY | ○ |
| | Self-diagnosis function | | ○ |
| | Extended part program editing | COPY, MOVE, CHANGE OF NC PROGRAM | ○ |
| Data input/output | Display screen | | 10.4" color |
| | Memory card input/output | | ○ |
| Editing operation | USB memory input/output | | ○ |
| | Part program storage size | 512Kbyte(1280m) | ○ |
| Manual guide i | Manual Guide i | | ○ |

SMEC

PL 60 series

HORIZONTAL TURNING CENTER



SMEC
SMEC CO.,LTD.

SMEC Co., Ltd.

157-10, Goldenroot-ro, Juchon-myeon, Gimhae-si, Gyeongsangnam-do, Korea

Tel +82 55 340 4800 Fax +82 55 340 4740

<http://www.esmec.com>



SMEC
SMEC CO.,LTD.

- 1988 - Started as Samsung Heavy Industries Machine Tools Business
- 1989 - Horizontal and vertical machining center technology partnership with OKK Japan
- 1991 - Turning center and vertical machining center technology partnership with Mori Seiki
- 1996 - 5-sided processing center technology partnership with Toshiba
- 1999 - Spun out from Samsung Aerospace Industries and established SMEC Co., Ltd

SMEC

Company
Engineering
Machine Tools
Samsung

PL 60/60M/60X/60XM PL 60L/60LM/60XL/60XLM

Strongest in class with superb structural design
Simultaneous heavy duty and precision turning

- 45 degree torque tube type bed to support heavy duty turning
- Significantly reduced non-cutting time and efficient turning
- Low-center of gravity reducing vibration, thermal deformation and improving rigidity

High Accuracy, High Rigidity Spindle

Main Spindle Motor and Gearing Headstock

The main spindle motor(45kW) speed is reduced to 2.5:1 and its power is delivered to the spindle through a three-speed geared headstock to provide powerful torque(560.7kg.m)

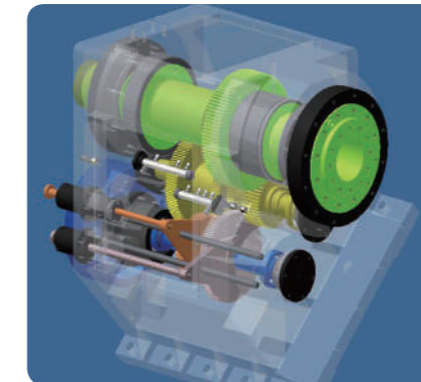
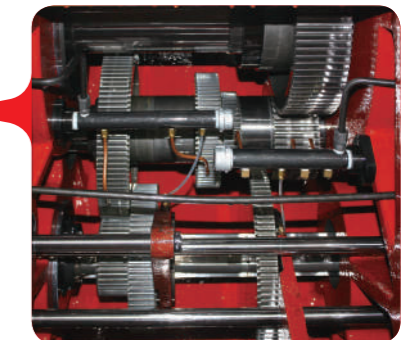
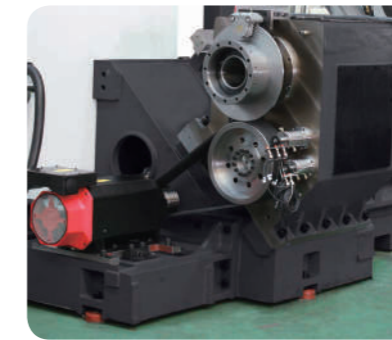

One Body Spindle and Headstock Construction for Minimal Thermal Expansion

The main spindle motor(45kW) speed is reduced to 2.5:1 and its power is delivered to the spindle through a three-speed geared headstock to provide powerful torque(560.7kg.m)

Spindle Power & Torque Diagram SL65, 65MC(24"Chuck)

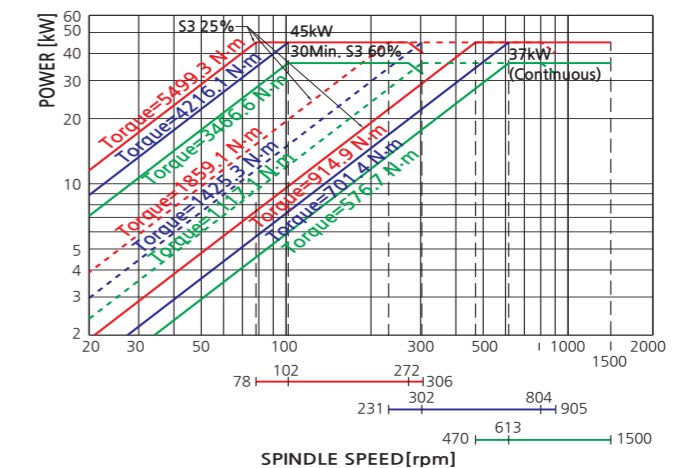

An innovative high precision, heavy duty CNC Lathe, integrated with all of SMEC's advanced technology
- PL 60 series

Spindle speed
1,500 rpm

Spindle motor(30min/cont.)
45/37 kW

Rapid traverse(X/Z)
12/18 m/min (PL 60/60M/60XL/60XLM)
12/15 m/min (PL 60X/60XM)
12/10 m/min (PL 60L/60LM)

Feed motor(X/Z)
4/9 kW

Max. machining length
1,000 mm (PL 60/60M)
2,070 mm (PL 60X/60XM)
3,200 mm (PL 60L/60LM)
5,050 mm (PL 60XL/60XLM)

Max. machining diameter
900 mm

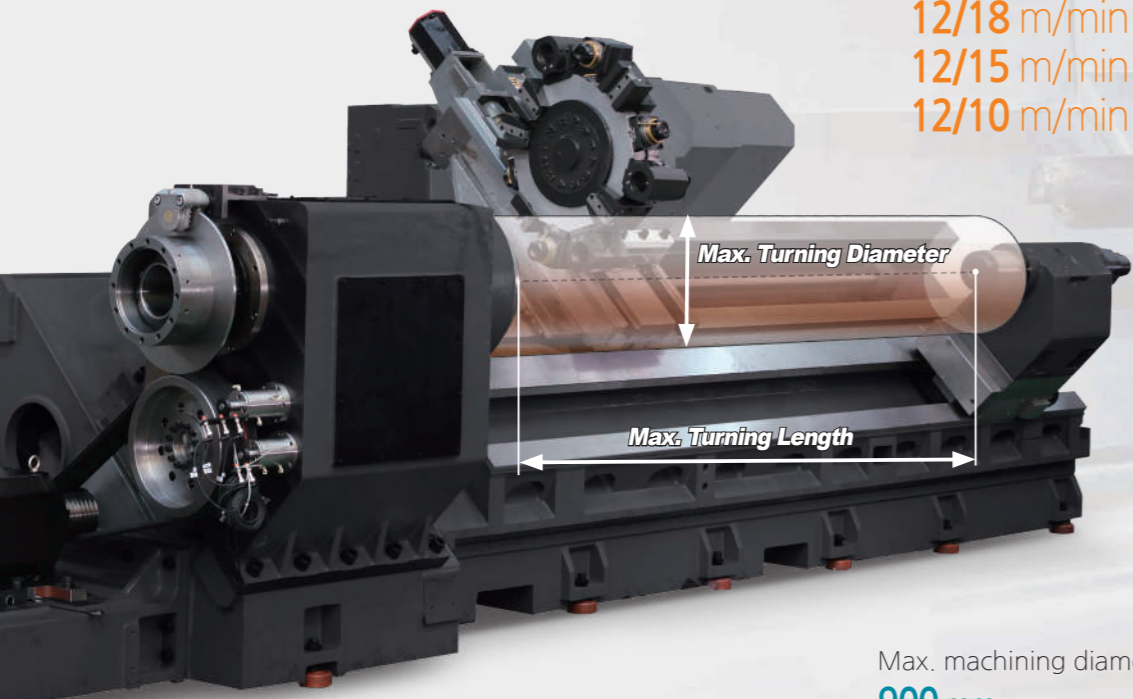

Highly Reliable and Rigid Structural Design

- One piece Meehanite casting with heavily ribbed torque tube design
- Rigid bed supports for powerful cutting
- Excellent vibration dampening and thermal displacement design

PL 60 (High Speed Servo Index Hydraulic Turret)

Indexing Time
0.25 sec(60 Hz)

Number of tool positions
12 stations

High Speed, Heavy Duty Servo Turret

Driven by a high torque servo motor, the 12-station heavy -duty turret can accept tools on both left and right side of each station. Turret indexing (repeatability ± 0.01) is non-stop, bi-directional with a fast 0.25 second next station index time. Large diameter (Ø287) precision Curvic coupling with 18,225kgf clamping force enables precision as well as heavy-duty cutting.

PL 60M (BMT High Speed Turret)

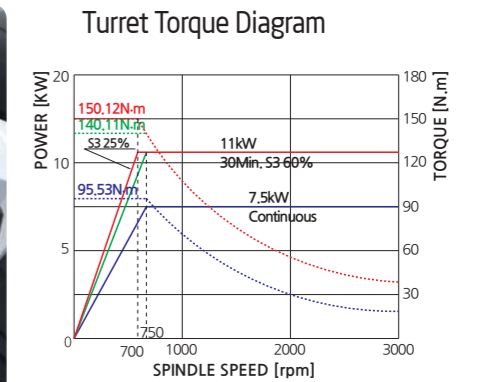

Indexing Time
0.25 sec(60 Hz)

Number of tool positions
12 stations

Milling Spindle Speed
3,000 rpm

Tool Holder
BMT 85

BMT Milling Turret (M Type)

PL60M is equipped with standard 12-station BMT turret capable of accepting rotary tools at any station, providing flexible machining thru various machining operations in just one set-up. Each BMT holder is securely tightened by 4 screws, allowing the turret to perform heavy-duty cutting, milling and drilling operations. Turret indexing is non-stop, bi-directional with a fast 0.25 second next station index time.

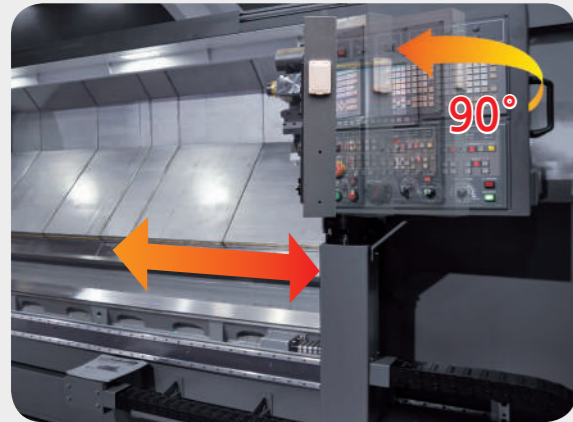

Centralized Operation Panel

The centralized operation panel with its 10.4 inch color TFT LCD monitor is able to swivel 90 degrees, providing operators with easy access to the control panel while working on the machine.



Rigid 45 degree Slant Bed

45 degree slant torque tube design bed and wide guide slide way ensure long term rigidity and machining accuracy. Also, the Slant Type structure allows for easier access to the workpiece and superb chip discharge.

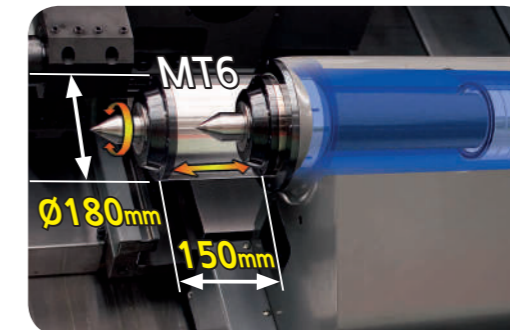
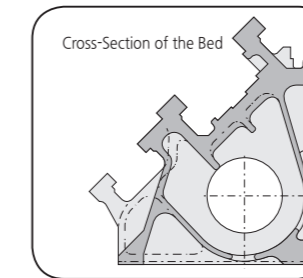

Programmable Tailstock (Carriage direct-coupled) [Std.]

The programmable tailstock body mounted is on wide guide ways to ensure rigid work piece support.

Pre-tensioned and Double Anchored Ballscrews

All axes ballscrews are pre-tensioned, heat treated and fixed by double anchors on both ends, providing ultimate rigidity and minimal thermal growth.

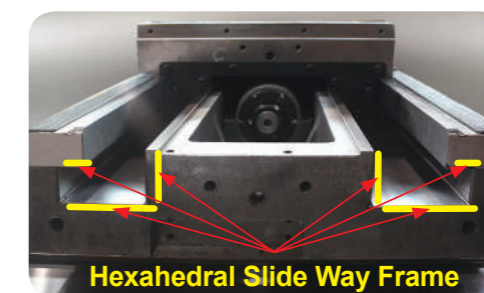
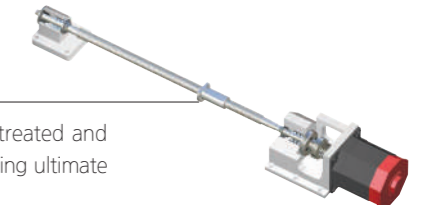

Hexahedral Slide Way Frame (X-axis)

Wide integral way is machined from the casting, induction hardened and precision ground to ensure long-term rigidity, machining accuracy and heavy-duty machining.

High Precision

Surface Roughness

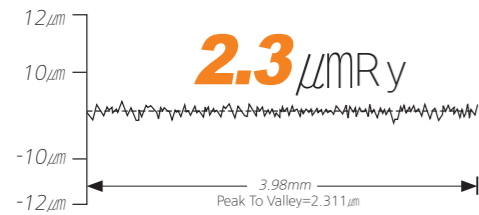

Model : PL 60L

Roundness

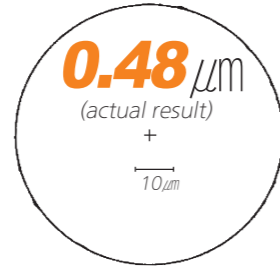

| Cutting condition | |
|-------------------|-------------------------------------|
| Tool | Diamond tool <nose radius 0.5mm> |
| Material | AL150<Aluminum> |
| Cutting speed | 230 m/min |
| Feedrate | 0.05 mm/rev |
| Depth of cut | 0.1 mm |
| Outer diameter | 200 mm |
| Filter | 1-50 |

Processing Speed

Turning Performance (material:SM45C) PL 60L

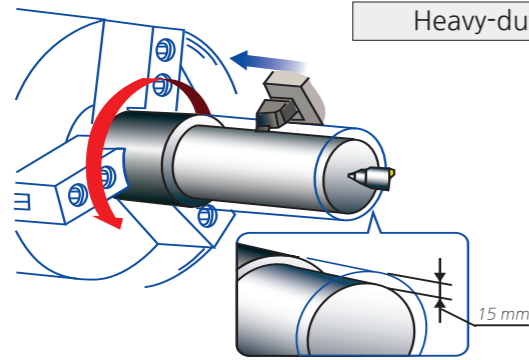

Heavy-duty cutting (O.D) <32mm×32mm qualified tool>

Spindle speed
367 rpm
Cutting speed
150 m/min
Depth of cut
15 mm <Spindle Load 65%>
Feedrate
0.4 mm/rev

Standard Accessories

Optional Accessories



Automatic Lubricator

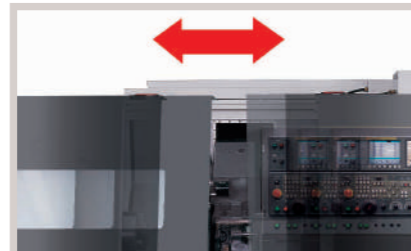

Auto Door



Tool Presetter

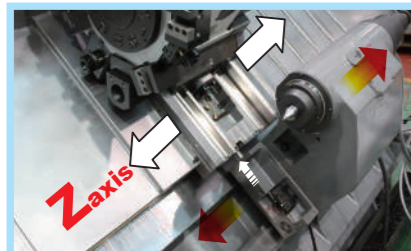

Programmable Tailstock

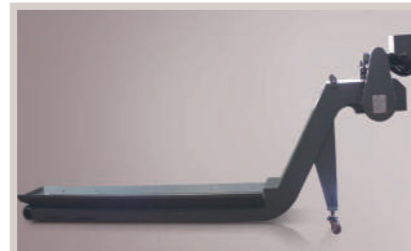

Chip Conveyor

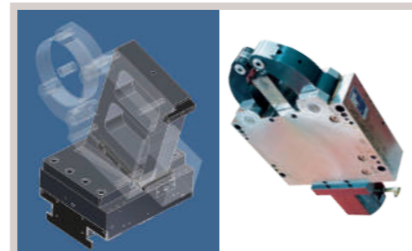

Steady Rest & Preparation

Tooling System

PL 60 / 60X / 60L / 60XL

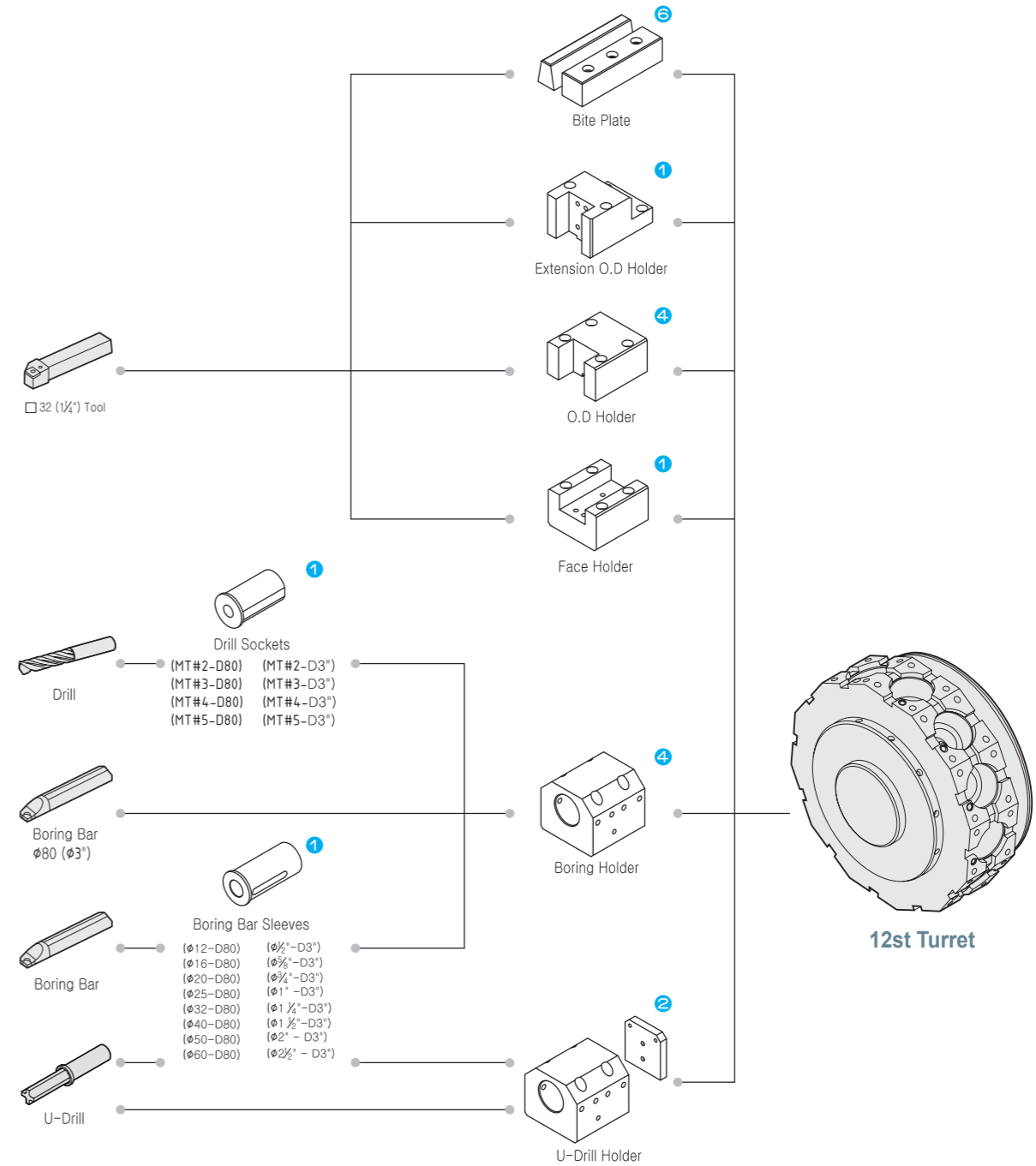

● : Standard Set Numbers

Tooling System

PL 60M / 60XM / 60LM / 60XLM

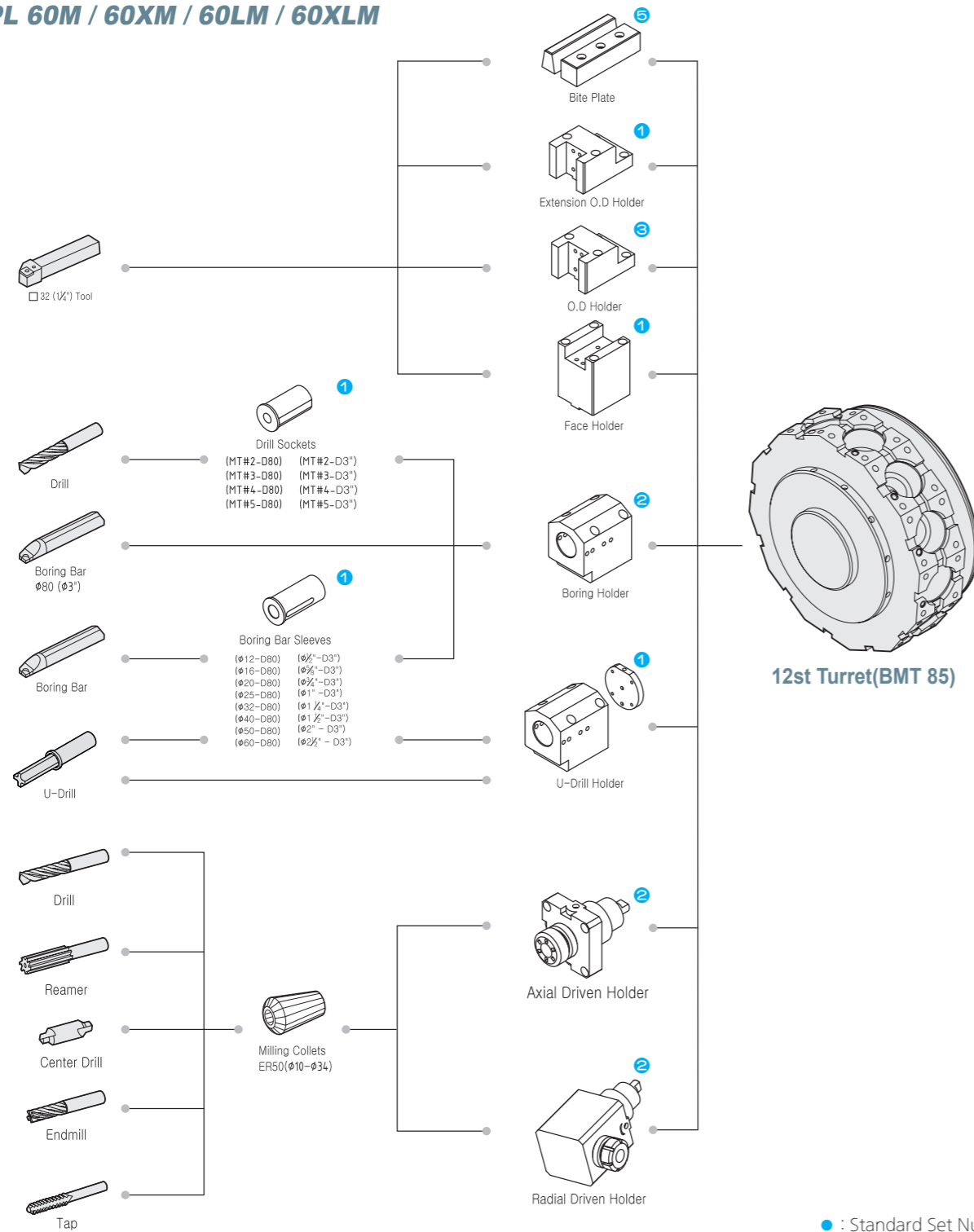

Machine Dimensions

Unit : mm

PL 60/60M

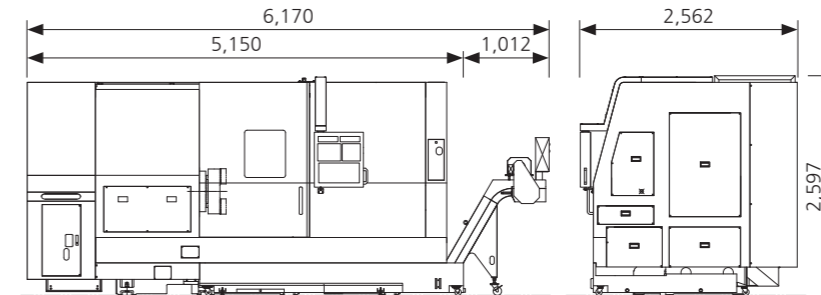

PL 60L/60LM

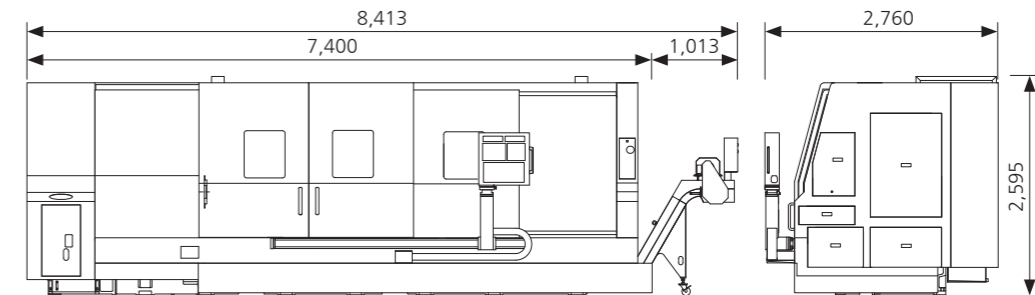

PL 60X/60XM

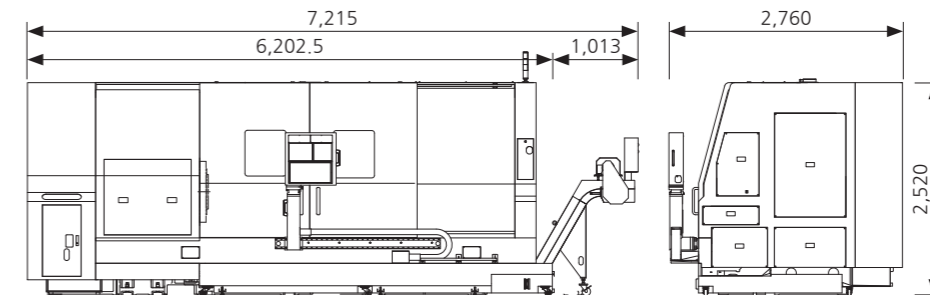

PL 60XL/60XLM

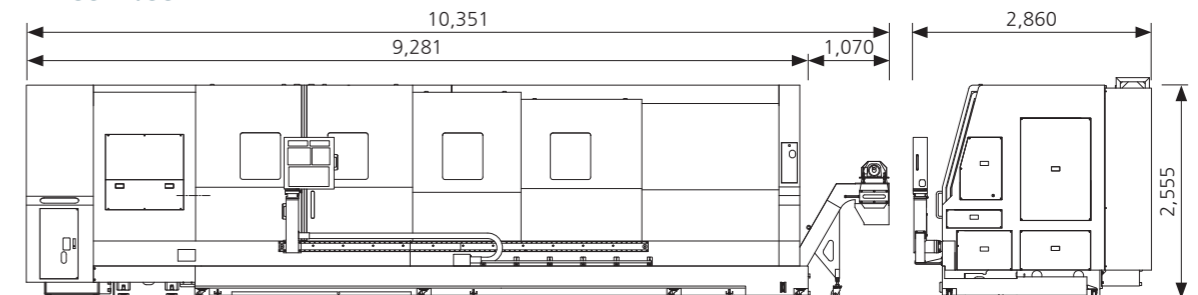

Work Range

Unit : mm

FACE CUT

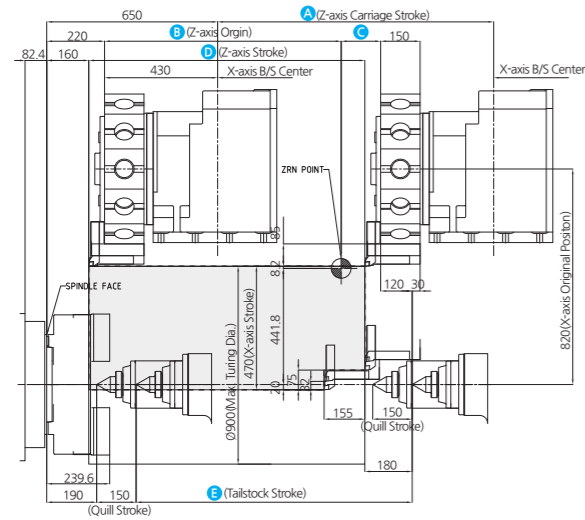

| | PL 60 | PL 60X | PL 60L | PL 60XL |
|---|---------|---------|---------|---------|
| A | 1,050mm | 2,050mm | 3,270mm | 5,100mm |
| B | 900mm | 1,900mm | 3,070mm | 4,900mm |
| C | 150mm | 150mm | 200mm | 200mm |
| D | 1,050mm | 2,050mm | 3,270mm | 5,100mm |
| E | 1,050mm | 2,050mm | 3,270mm | 5,100mm |

BORING CUT

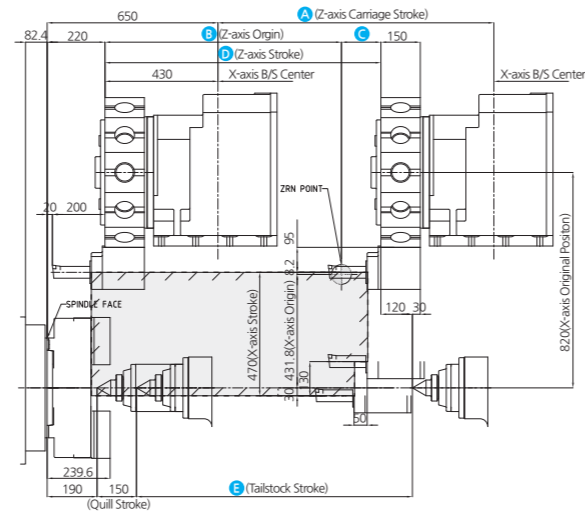

| | PL 60 | PL 60X | PL 60L | PL 60XL |
|---|---------|---------|---------|---------|
| A | 1,050mm | 2,050mm | 3,270mm | 5,100mm |
| B | 900mm | 1,900mm | 3,070mm | 4,900mm |
| C | 150mm | 150mm | 200mm | 200mm |
| D | 1,050mm | 2,050mm | 3,270mm | 5,100mm |
| E | 1,050mm | 2,050mm | 3,270mm | 5,100mm |

BORING & RADIAL DRIVEN

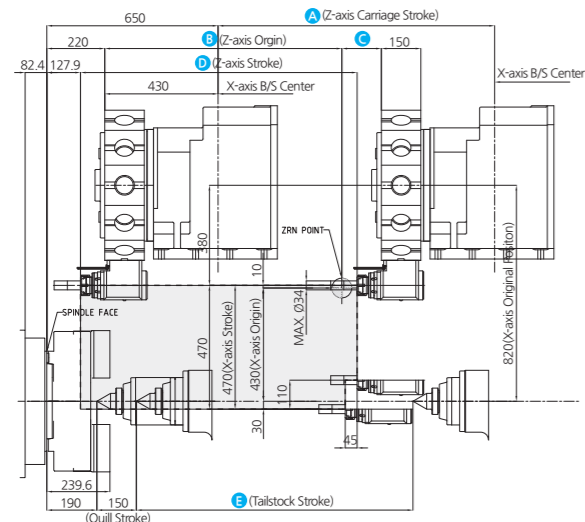

| | PL 60M | PL 60XM | PL 60LM | PL 60XLM |
|---|---------|---------|---------|----------|
| A | 1,050mm | 2,050mm | 3,270mm | 5,100mm |
| B | 900mm | 1,900mm | 3,070mm | 4,900mm |
| C | 150mm | 150mm | 200mm | 200mm |
| D | 1,050mm | 2,050mm | 3,270mm | 5,100mm |
| E | 1,050mm | 2,050mm | 3,270mm | 5,100mm |

FACE & AXIAL DRIVEN

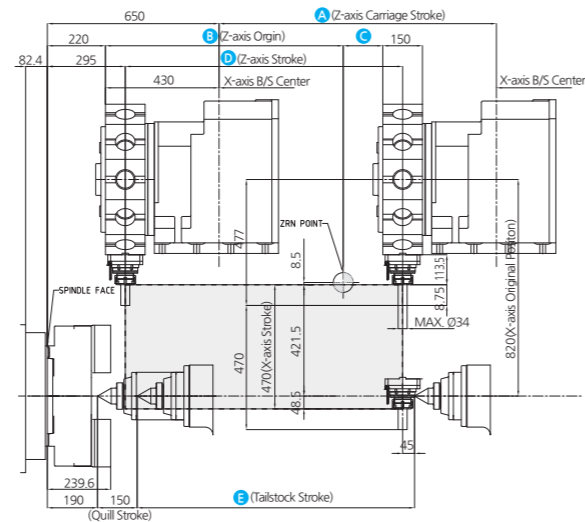

| | PL 60M | PL 60XM | PL 60LM | PL 60XLM |
|---|---------|---------|---------|----------|
| A | 1,050mm | 2,050mm | 3,270mm | 5,100mm |
| B | 900mm | 1,900mm | 3,070mm | 4,900mm |
| C | 150mm | 150mm | 200mm | 200mm |
| D | 1,050mm | 2,050mm | 3,270mm | 5,100mm |
| E | 1,050mm | 2,050mm | 3,270mm | 5,100mm |

Turret Head Interference

Unit : mm

PL 60/60X/60L/60XL (STD 12 station)

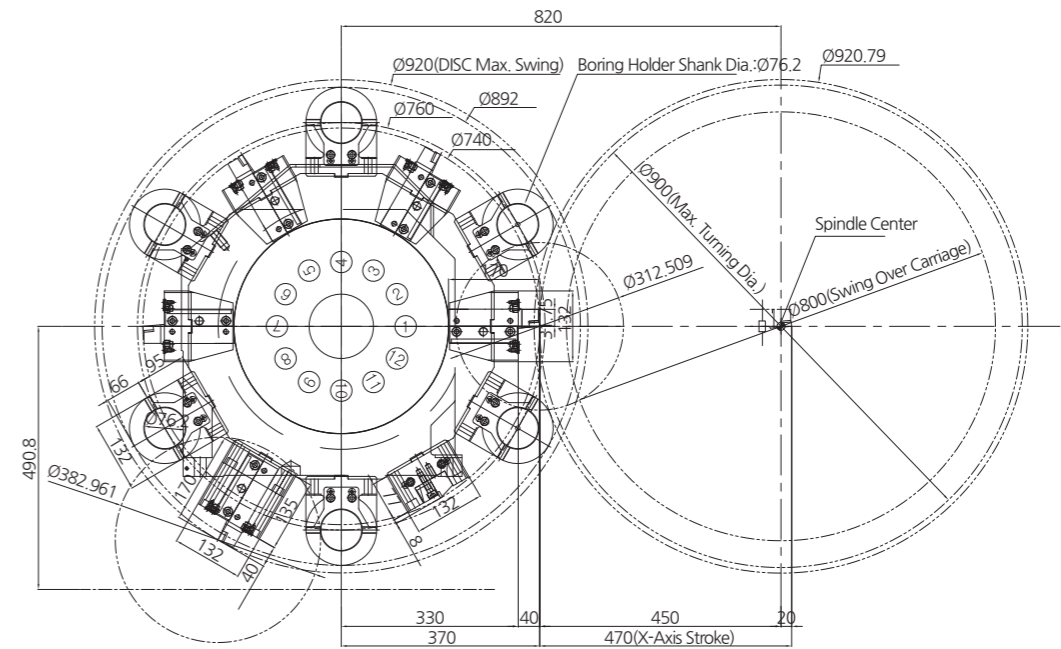

PL 60M/60XM/60LM/60XLM (BMT 75)

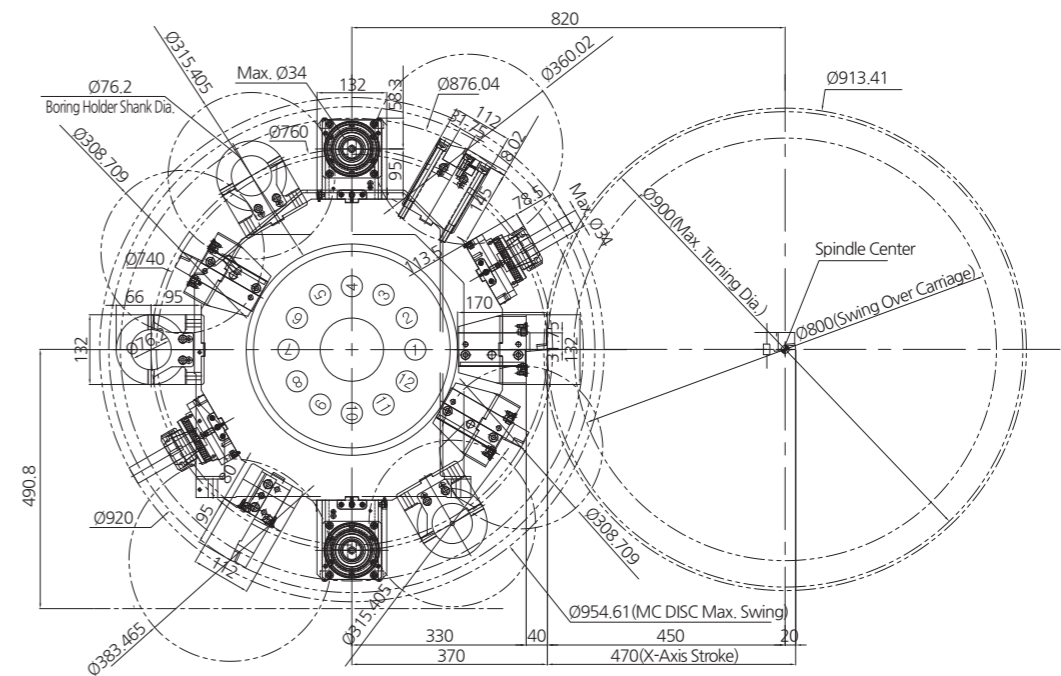

Major Specifications

| DESCRIPTION | | PL 60 | PL 60M | PL 60X | PL 60XM |
|---------------------------|--|-------------|-----------------|-----------------|-----------------|
| Capacity | Swing over the bed | mm | 1,030 | 1,030 | 1,030 |
| | Swing over the cross slide | mm | 800 | 800 | 800 |
| | Recom. turning diameter | mm | 530 | 530 | 530 |
| | Max. turning diameter | mm | 900 | 900 | 900 |
| | Max. turning length | mm | 1,000 | 1,000 | 2,000 |
| | Bar working diameter | mm | 139 | 139 | 139 |
| Travels | X axis travel | mm | 470 | 470 | 470 |
| | Z axis travel | mm | 1,050 | 1,050 | 2,050 |
| Main Spindle | Max. spindle speed | rpm | 1,500 | 1,500 | 1,500 |
| | Chuck size | inch | 21" | 21" | 21" |
| | Spindle nose | ASA | A2-15 | A2-15 | A2-15 |
| | Spindle through hole diameter | mm | Ø152 | Ø152 | Ø152 |
| | Min. spindle indexing angle(C-Axis) | deg | - | 0.001 | - |
| Turret (STD.) | Number of tool stations [option] | ea | 12(STD) | 12(STD) | 12(STD) |
| | Shank size for square tool | mm | □ 32 | □ 32 | □ 32 |
| | Shank diameter for boring bar | mm | Ø80 | Ø80 | Ø80 |
| Turret (MC) | Number of tool stations [option] | ea | 12 | 12(BMT85) | 12(BMT85) |
| | Shank size for square tool | mm | □ 32 | □ 32 | □ 32 |
| | Shank diameter for boring bar | mm | Ø80 | Ø80 | Ø80 |
| | Indexing time | sec | 0.25 | 0.25 | 0.25 |
| | Rotary tool spindle speed | rpm | - | 3,000 | - |
| Feed Rate | Rapid traverse (X/Z) | m/min | 12 / 18 | 12 / 18 | 12 / 15 |
| | Feed per revolution | mm/rev | 0.0016~500 | 0.0016~500 | 0.0016~500 |
| Motor | X axis feed motor | kW | 7 | 7 | 7 |
| | Z axis feed motor | kW | 6 | 6 | 6 |
| | Spindle drive motor(cont./30min) | kW | 37 / 45 | 37 / 45 | 37 / 45 |
| | Rotary tool spindle motor(cont./30min) | kW | - | 7.5 / 11 | - |
| Tailstock | Tailstock travel | mm | 1,050 | 1,050 | 2,050 |
| | Quill diameter | mm | Ø180 | Ø180 | Ø180 |
| | Quill bore taper | MT | MT-6 (BUILT-IN) | MT-6 (BUILT-IN) | MT-6 (BUILT-IN) |
| | Quill travel | mm | 150 | 150 | 150 |
| ELECTRIC POWER SUPPLY | kVA/V | 65 | 69 | 65 | 69 |
| REQUIRED FLOOR SPACE(L×W) | mm | 5,158×2,564 | 5,158×2,564 | 6,203×2,760 | 6,203×2,760 |
| MACHINE WEIGHT | kg | 16,500 | 16,500 | 19,000 | 19,000 |
| CONTROLLER | | Fanuc Oi-TF | | | |

※Figures in inches are converted from metric measurements.

Major Specifications

| DESCRIPTION | | PL 60L | PL 60LM | PL 60XL | PL 60XLM |
|---------------------------|--|-------------|-----------------|-----------------|-----------------|
| Capacity | Swing over the bed | mm | 1,030 | 1,030 | 1,030 |
| | Swing over the cross slide | mm | 800 | 800 | 800 |
| | Recom. turning diameter | mm | 530 | 530 | 530 |
| | Max. turning diameter | mm | 900 | 900 | 900 |
| | Max. turning length | mm | 3,200 | 3,200 | 5,050 |
| | Bar working diameter | mm | 139 | 139 | 139 |
| Travels | X axis travel | mm | 470 | 470 | 470 |
| | Y axis travel | mm | 3,270 | 3,270 | 5,100 |
| Main Spindle | Max. spindle speed | rpm | 1,500 | 1,500 | 1,500 |
| | Chuck size | inch | 21" | 21" | 21" |
| | Spindle nose | ASA | A2-15 | A2-15 | A2-15 |
| | Spindle through hole diameter | mm | Ø152 | Ø152 | Ø152 |
| Turret (STD.) | Min. spindle indexing angle(C-Axis) | deg | - | 0.001 | - |
| | Number of tool stations [option] | ea | 12(STD) | 12(STD) | 12(STD) |
| | Shank size for square tool | mm | □ 32 | □ 32 | □ 32 |
| | Shank diameter for boring bar | mm | Ø80 | Ø80 | Ø80 |
| | Indexing time | sec | 0.25 | 0.25 | 0.25 |
| Turret (MC) | Rotary tool spindle speed | rpm | - | 3,000 | - |
| | Number of tool stations [option] | ea | 12 | 12(BMT85) | 12(BMT85) |
| | Shank size for square tool | mm | □ 32 | □ 32 | □ 32 |
| | Shank diameter for boring bar | mm | Ø80 | Ø80 | Ø80 |
| Feed Rate | Rapid traverse (X/Z) | m/min | 12 / 10 | 12 / 10 | 12 / 10 |
| | Feed per revolution | mm/rev | 0.0016~500 | 0.0016~500 | 0.0016~500 |
| Motor | X axis feed motor | kW | 7 | 7 | 7 |
| | Z axis feed motor | kW | 6 | 6 | 6 |
| | Spindle drive motor(cont./30min) | kW | 37 / 45 | 37 / 45 | 37 / 45 |
| | Rotary tool spindle motor(cont./30min) | kW | 7.5 / 11 | 7.5 / 11 | 7.5 / 11 |
| Tailstock | Tailstock travel | mm | 3,270 | 3,270 | 5,100 |
| | Quill diameter | mm | Ø180 | Ø180 | Ø180 |
| | Quill bore taper | MT | MT-6 (BUILT-IN) | MT-6 (BUILT-IN) | MT-6 (BUILT-IN) |
| | Quill travel | mm | 150 | 150 | 150 |
| ELECTRIC POWER SUPPLY | kVA/V | 65 | 69 | 65 | 69 |
| REQUIRED FLOOR SPACE(L×W) | mm | 7,400×2,760 | 7,400×2,760 | 9,400×2,860 | 9,400×2,860 |
| MACHINE WEIGHT | kg | 22,000 | 22,000 | 26,000 | 26,000 |
| CONTROLLER | | Fanuc Oi-TF | | | |

※Figures in inches are converted from metric measurements.

Standard Accessories

- Coolant System (4.5bar-60Hz)
- Built-In Work Light
- Splash Guard
- Hand Tools
- 21" Hydraulic Chuck
- Soft Jaw 3 Sets
- Hard Jaw 1 Set
- Turret Holder
- Levelling Block
- Programmable Tailstock
- Spindle Orientation
- Door Interlock
- Chuck Clamp Confirmation
- * Door Interlock, Chuck Clamp Confirmation are CE, KCS standard.

Optional Accessories

- Chip Conveyor With Bucket
- Steadyrest : SLU-5 ZS, SLU-5.1
- Dual Steadyrest : SLU-5 ZS, SLU-5.1
- Autodoor & Edge Sensor
- High Pressure Coolant (6,10,15 Bar-60Hz)
- Oil Skimmer
- Coolant Gun
- Air Blower
- Transformer
- Patrol Lamp